

# FARM-FLEET

- 2015 CATALOGUE -



**COMMERCIAL**

**LANDSCAPING**

**CONSTRUCTION**

**ROCK EQUIPMENT**

**AGRICULTURE**

**FORESTRY**

## INDEX

- Aerators . . . . . 42, 69, 71  
ATV Box Scrapers . . . . . 98  
ATV Carts . . . . . 62-64  
ATV Discs . . . . . 96-97  
ATV Land Plane . . . . . 97  
ATV Landscape Rake . . . . . 98  
ATV Scraper Blades . . . . . 98  
ATV Seeder . . . . . 79, 83  
ATV Snowblower . . . . . 41  
ATV Snow Plow . . . . . 40  
ATV Spreader . . . . . 75, 78-79  
Bale Forks & Spears . . . . .  
. . . . . 124-130  
Box Scrapers . . . . . 50-55  
Canopies . . . . . 146-147  
Carts . . . . . 62-64  
Cement Mixers . . . . . 61  
Chain Harrows . . . . . 99  
Chipper/Shredders . . . . . 112  
Core Aerators . . . . . 42, 70  
De-Thatcher . . . . . 65, 69  
Discs (also see ATV Discs)  
. . . . . 140-145  
Engine Driven Mowers . . . . .  
. . . . . 17-18  
Engine Driven Snowblower  
. . . . . 41  
Engine Driven Tillers . . . . . 30  
Estate Sprayers . . . . . 90-94  
Fertilizer Spreaders . . . . . 74-89  
Finishing Mowers . . . . . 17-22  
Flail Mowers . . . . . 26-29  
Flex Mower . . . . . 23-25  
Foam Markers . . . . . 95  
Grapple Bucket . . . . . 115, 118  
Grapple Rake . . . . . 113-114  
Harrows . . . . . 99  
Hay Handling . . . . . 122-130  
Hay Rakes . . . . . 122-123  
Hydraulic Top Link . . . . . 148  
Land Plane . . . . . 56  
Landscape Rakes . . . . . 58-60  
Lawn Rollers . . . . . 72, 73  
Lawn Sweepers . . . . . 66-67  
Lawn Vac . . . . . 68  
Log Grapples . . . . . 113-115, 118  
Log Splitters . . . . . 108-110  
Logging Winches . . . . . 106-107  
Manure Forks . . . . . 119  
Manure Spreaders . . . . . 100  
Mixers (Cement) . . . . . 61  
Moldboard Plow . . . . . 132  
Mowers . . . . . 15-28  
Offset Discs . . . . . 141-145  
Overseeder . . . . . 38-39  
Packers . . . . . 133  
Pallet Forks . . . . . 120-121  
Plows . . . . . 132, 138-139  
Post Drivers . . . . . 136-137  
Post Hole Diggers . . . . . 134-135  
Potato Planter/Hiller/Digger  
. . . . . 131  
Powered Landscape Rake  
. . . . . 58-59  
Pulverizers . . . . . 37  
Quick Attach Brackets . . . . .  
. . . . . 115, 149  
Quick Hitches 3 Pt. . . . . 148  
Rakes (Grapple) . . . . . 113-114  
Rakes (Hay) . . . . . 122-123  
Rakes (Landscape) . . . . . 60  
Rakes (Rock) . . . . . 101  
Rippers . . . . . 138-139  
Rock Buckets . . . . . 116-117

# INDEX



Rock Rakes . . . . .	101
Rollers . . . . .	69, 72-73
Rotary Broom . . . . .	150-151
Rotary Cutters . . . . .	6-14
Rotary Tillers . . . . .	30-36
Scraper Blades . . . . .	43-46
Sickle Bar Mower . . . . .	15
Skid Steer - Adaptor . . . . .	149
Skid Steer - Rotary Brooms . . . . .	151
Skid Steer Blades . . . . .	47-48
Skid Steer Grapple . . . . .	114-118
Snow Blades . . . . .	47-49
Snowblowers . . . . .	41
Spiker / Aerator . . . . .	7, 173
Spray Foam Markers . . . . .	95
Sprayers . . . . .	90-94
Spreaders . . . . .	74-89
Stone Forks . . . . .	116-117
String Trimmer . . . . .	16
Stump Grinder . . . . .	111
Sub-Soilers . . . . .	138-139
Sweepers . . . . .	66-67
Tillers . . . . .	30-36
Tractor Canopies . . . . .	146-147
Tree Saw . . . . .	105
Tree Shears . . . . .	102-103
Vacuums . . . . .	68
Winches . . . . .	106-107

Aerators . . . . .	69-71
ATV Dump Carts . . . . .	62, 64
ATV Snowblower . . . . .	41
Carts . . . . .	62, 64
Core Aerators . . . . .	70
De-Thatcher . . . . .	65
Fertilizer Spreaders . . . . . . . . . .	74, 75, 78, 80
Lawn Rollers . . . . .	69, 72
Lawn Sweepers . . . . .	67
Lawn Vac . . . . .	68
Rollers . . . . .	69, 72
Smart Link - Attachments . . . . . .	69
Snowblowers/Snow Plows . . . . .	40-41
Spike Aerators . . . . .	71
Spreaders . . . . .	74, 75, 78, 80
Sweepers . . . . .	67
Tillers . . . . .	30
Tractor Carts . . . . .	62, 64
Vacuums . . . . .	68

**INDEX CONTINUED  
ON NEXT PAGE.....**



We reserve the right to correct printing errors, limit quantities or make merchandise substitutions. Pictures are representative only and may vary from actual product. Prices subject to change without notice. Prices maybe subject to additional freight & set-up charges. Not all products stocked at all locations. F.O.B. St. Marys, Ontario unless otherwise stated.

# TABLE OF CONTENTS



[www.amazone.de](http://www.amazone.de)

Spreaders . . . . . 88, 89

## BARE-Co

[www.bare-co.com](http://www.bare-co.com)

Tractor Canopies . . . . . 146-147



[www.befco.com](http://www.befco.com)

Aerator/Overseeder Green Rite .	38
Baby Hop Ground Driven . . . . .	84
"Chipper 6"" . . . . .	112
Core Aerators . . . . .	42
Finishing Mowers . . . . .	
Engine Driven Finish Mower . .	18
C30 Series . . . . .	20
C50 Series . . . . .	21
C70 Series . . . . .	22
Flex Mowers . . . . .	23-25
Flail Mowers . . . . .	
H40 Series, Hurricane . . . . .	26
H70 Series, Hurricane . . . . .	27
H80 Series, Hurricane . . . . .	28
Flail Shredder . . . . .	29
Hay rakes . . . . .	123
Overseeders . . . . .	38-39
Rotary Tillers . . . . .	
T30 Series . . . . .	32
T40 Series . . . . .	33
T50 Series . . . . .	34
T60 Series . . . . .	35
T70 Series . . . . .	36
Soil Pulverizers . . . . .	37
Spreaders . . . . .	84,85,87
Turbo Hop Spreader . . . . .	87



[www.brownmanufacturing.com](http://www.brownmanufacturing.com)

Rotary Cutters HD & ExtraHD 10,12	
Rotary Cutters Tree Cutter . . . . .	14
Tree Saw . . . . .	105



Sickle Bar Mower . . . . . 15



[www.fimcoindustries.com](http://www.fimcoindustries.com)

Dump Carts . . . . .	63
Estate Sprayers . . . . .	90-94
Manure Spreader . . . . .	100
Spreaders - Broadcast . . . . .	79,82



[www.fransgard.dk](http://www.fransgard.dk)

Accessories - Winch . . . . .	107
Logging Winches . . . . .	106
Rake, Hay . . . . .	122
Rotary Cutter Chain Mulcher . . .	13

## Hackett Harrows

Chain Harrows . . . . . 99



[www.shoule.com](http://www.shoule.com)

Grapple Rake . . . . .	115
Tree Shears . . . . .	102-103
Rock Buckets . . . . .	116-117
Rock Rakes . . . . .	101



Box Scrapers . . . . .	50
Landscape Rake . . . . .	60
Moldboard Plow 3 Pt . . . . .	132
Rotary Cutters . . . . .	8,9,11
Scraper Blades . . . . .	43-44

# TABLE OF CONTENTS



[www.monroetufline.com](http://www.monroetufline.com)

42 Series Discs	144-145
ATV	
Box Scrapers	98
Discs Harrows	96-97
Land Plane	97
Landscape Rake	98
Scraper Blade	98
3 Pt. Box Scraper	51-54
Pull Type Box Scraper	55
Land Plane	56
Offset Discs	141, 144-145
Packers 3 Pt.	133
Scraper Blades	45
Sub-Soilers	139
THE Series	140
TLO Series	141
TW6 Series	142-143



**ROTOMECC**

Rotary Tillers	31
----------------	----



Finishing Mower	17
Rotary Cutter	6-7
String Trimmer	16



Logsplitters	108-110
--------------	---------

**TrailLine**

Spray Foam Markers	95
--------------------	----



**WORKSAVER**

[www.worksaver.com](http://www.worksaver.com)

ATV Seeder Spreader	83
Cement Mixers	61
Euro to Skid Steer Adaptor	149
Grapples	113-114, 118
Hay Handling Attachments	124-130
Hydraulic Top Link	148
Landscape Rakes	60
Manure Forks	119
Pallet Forks	120-121
Post Drivers 3Pt. & Skid Steer	136-137
Powered Landscape Rake	58-59
Post Hole Diggers	134-135
Quick Hitches 3 Pt.	148
Rippers Single Shank	138
Rotary Broom	150-151
Snow Blades	47-49
Stump Grinder	111
Weld On Euro/global ALO Quick Attach	149



Core Aerators	70
Lawn Sweepers	66
Spiker Spreader	81
Spreader - Broadcast	76-77
Sweepers	66
Roller/Spiker	73

**FARM-FLEET INC.**

We reserve the right to correct printing errors, limit quantities or make merchandise substitutions. Pictures are representative only and may vary from actual product. Prices subject to change without notice. Prices maybe subject to additional freight & set-up charges. Not all products stocked at all locations. F.O.B. St. Marys, Ontario unless otherwise stated.

# ROTARY CUTTER

## Engine Driven

## Walk Behind

**SWISHER<sup>®</sup>**

The SWISHER walk behind Trailcutter mower is perfect for cutting trails through the woods and clearing fields and ditches. It will clear the densest undergrowth and saplings up to 1-1/2" in diameter. This self-propelled walk-behind features a 11-1/2 HP Briggs & Stratton Engine and a heavy duty fabricated deck. It's single, fixed hardened steel blade cuts through brush and saplings with ease. The blade is enclosed for maximum safety. Front and side safety deflectors protect against flying debris. Handlebar mounted controls are easily accessed for total control and safety. Proper safety attire and eye protection should be used. Large chevron tread pneumatic tires roll easily over the roughest terrain for smooth cutting in all conditions. A four speed transmission is great for climbing or cruising and the reverse gear is handy for easy backing up.

- \* **24" Cutting Width**
- \* **11.5 HP B&S Engine**
- \* **Manual recoil start**
- \* **4 Speed transmission with neutral & reverse**
- \* **Tires two 4.80 x 8 pneumatic tires**
- \* **One H.D. hardened steel fixed blade**
- \* **Up to 1-1/2" sapling cutting diameter**
- \* **Cutting height, Variable**
- \* **.7 US gallon fuel capacity**
- \* **Handlebar drive controls**
- \* **Handlebar manual PTO clutch**
- \* **Proper Safety Attire is recommended**

<b>MODEL</b>	<b>DESCRIPTION</b>	<b>WEIGHT</b>	<b>LIST PRICE</b>
WBRC11524C	11.5 HP, 24" walk behind Rotary Cutter	288 lbs.	\$2599

# ROTARY CUTTER

## Engine Driven

## Pull Type



SWISHER rough cut Trailcutter is perfect for any big mowing job. Backed by the power of 60 + years of design experience, this mower is designed to dramatically reduce mowing time. The SWISHER Trailcutter easily attaches to your ATV, UTV or lawn tractor. These models will cut saplings up to 3" in diameter and thick brush with two heavy duty swinging blades. A convenient single point cutting height adjustment with a 4" range on 44" model and 2.5" - 7" on 52" model. The remote control operator console on the 52" model lets you safely engage and disengage the mower blades from your ATV or tractor seat.

- \* Offsets, left/right/center articulating
- \* Two 4.00 x 8" pneumatic tires with sealant on 44"
- \* Four 13x5x6 puncture resistant semi-pneumatic tires on 52"
- \* Two H.D. hardened steel swinging blades
- \* Up to 3" sapling cutting diameter
- \* 2.5 US gallon fuel capacity
- \* 44" clevis/pin type hitch
- \* 52" 2" trailer hitch ball coupler
- \* 12V electric start
- \* 44" manual PTO Clutch
- \* 52" electric PTO Clutch
- \* Remote Operator Control Console
- \* 12V battery EXTRA (not included)

MODEL	DESCRIPTION	WEIGHT	LIST PRICE
RC14544BS	44", 14.5 HP B&S engine Electric start, 2 wheel	400 lbs.	\$3069
RC17552BS	52", 17.5 HP B&S engine Electric start, 4 wheel	587 lbs.	\$4459

# ROTARY CUTTERS

## 3 Pt. PTO

### 1100 Series



These affordable rotary cutters built by TITAN Implement are ideal for the cutting of grass, weeds and light brush up to 1" diameter. These units feature a 12 ga. deck, CAT. I - 3 Pt. Hitch, and 540 RPM shear pin PTO. Manufactured in U.S.A.

- \* Cat I, 3 Pt hitch
- \* Series 4 Shear pin PTO shaft with PTO shielding
- \* 1/4" round formed steel blade carrier (stump jumper)
- \* Single 4" x 15" solid laminated rubber tire
- \* Regreaseable cast wheel hub
- \* 55 HP rated gear box
- \* 12 ga. Steel deck with 7" high sides
- \* 1" cutting capacity
- \* Optional safety guard chains available

MODEL	MAXIMUM PTO HP	CUTTING WIDTH	WEIGHT	LIST PRICE
1104	45 HP	48" / 4'	524 lbs.	\$1199
1105	45 HP	60" / 5'	584 lbs.	\$1239
1106	65 HP	72" / 6'	712 lbs.	\$1595

The manufacturer highly recommends the use of optional safety guard chains.

#### OPTIONS:

MODEL	DESCRIPTION	LIST PRICE
CG1104	48" / 4' Safety guard chain kit	\$329
CG1105	60" / 5' Safety guard chain kit	\$395
CG1106	72" / 6' Safety guard chain kit	\$425



# ROTARY CUTTERS

## 3 Pt. PTO

### 1400 Series

### Medium Duty



Unit shown with optional safety chains

These affordable rotary cutters built by TITAN Implement are ideal for the cutting of grass, weeds and light brush up to 2" diameter. These units feature a 11 ga. deck, CAT. I - 3 Pt. Hitch, and 540 RPM PTO with slip clutch. Manufactured in U.S.A.

- \* Cat I, 3 Pt hitch
- \* Series 4 Slip clutch PTO shaft with PTO shielding
- \* 1/4" round formed steel blade carrier (stump jumper)
- \* Single 4" x 15" solid laminated rubber tire
- \* Regreaseable cast wheel hub
- \* 100 HP rated gear box
- \* 11 ga. Steel deck with 7" high sides
- \* Flat bar and formed channel deck reinforcing
- \* 2" cutting capacity
- \* Optional safety guard chains available

MODEL	MAXIMUM PTO HP	CUTTING WIDTH	WEIGHT	LIST PRICE
1405SC	90 HP	60" / 5'	689 lbs.	\$1739
1406SC	90 HP	72" / 6'	820 lbs.	\$2039

The manufacturer highly recommends the use of optional safety guard chains.

#### OPTIONS:

MODEL	DESCRIPTION	LIST PRICE
CG1105	60" / 5' Safety chain guard kit	\$395
CG1106	72" / 6' Safety chain guard kit	\$425

# ROTARY CUTTERS

## 410 SERIES

### HEAVY DUTY 3 Pt.



415



417

With over 50 years of innovative design and production, BROWN Mfg. has set the standard for heavy duty rotary cutters. The 410 series rotary cutter comes with a 130 HP rated gearbox, with limited 5 year warranty. Available in four sizes, 5', 6', 7' & 8' with a slip-clutch PTO Shaft. This heavy duty cutter is tough enough to cut heavy brush and trees up to 2" in diameter.

- \* Deck Design, round back, reinforced
- \* Deck Construction, all welded 7 gauge (3/16") steel
- \* 130 HP rated gearbox, limited 5 year warranty
- \* Cat. 5 Slip-clutch PTO shaft on 5' & 6' models
- \* Cat. 6 - 4 Disc slip-clutch PTO shaft on 7' and 8' models
- \* Laminated solid rubber tail wheels
- \* 5' & 6' single tail wheel
- \* 7' & 8' dual tail wheels
- \* 5' & 6' Cat. I/II clevis style 3 Pt. hitch
- \* 7' Cat. II, 8' Cat. II / III clevis style 3 Pt. Hitch
- \* Stump Jumper 3/16" with 1" x 5" solid bar
- \* 1/2" x 4" heat treated/up draft type blades
- \* Replaceable slides
- \* Replaceable front rubber deflector
- \* Optional chain guards available

MODEL	DESCRIPTION	WEIGHT	LIST PRICE
415	5' Rotary Cutter, Single Tail Wheel	900 lbs.	\$3365
416	6' Rotary Cutter, Single Tail Wheel	1060 lbs.	\$3955
417	7' Rotary Cutter, Dual Tail Wheel	1375 lbs.	\$5655
418	8' Rotary Cutter, Dual Tail Wheel	2096 lbs.	\$6595

#### OPTIONS:

MODEL	DESCRIPTION	WEIGHT	LIST PRICE
4-007	5' Front Chain Guard	53 lbs.	\$319
232-0031	5' Rear Chain Guard	21 lbs.	\$265
4-009	6' Front Chain Guard	57 lbs.	\$339
232-0030	6' Rear Chain Guard	37 lbs.	\$285
4-011	7' Front Chain Guard	67 lbs.	\$359
232-0032	7' Rear Chain Guard	42 lbs.	\$359
232-0830	8' Front Chain Guard	84 lbs.	\$440
232-0850	8' Rear Chain Guard	57 lbs.	\$399

# ROTARY CUTTERS

**3 Pt. PTO**

**1500 Series (7')**

**1700 Series (8')**

**Medium Duty**



These affordable rotary cutters built by TITAN Implement are ideal for the cutting of grass, weeds and light brush up to 2" diameter. These units feature a 10 ga. (7'), 11 ga. (8') deck, CAT. II - 3 Pt. Hitch, and 540 RPM PTO with slip clutch. Manufactured in U.S.A.

- \* Cat I, 3 Pt hitch
- \* Series 6 Slip clutch PTO shaft with PTO shielding on 7' model
- \* Series 5 Slip clutch PTO shaft with PTO shielding on 8' model
- \* 5/8" round formed steel blade carrier (stump jumper)
- \* 7 ft Single wheel with 4" x 15" solid laminated rubber tire
- \* 8 ft Dual wheels with 4" x 15" solid laminated rubber tire
- \* Regreaseable cast wheel hub
- \* 100 HP rated gear box on 7' model
- \* 150 HP rated gear box on 8' model
- \* 100 HP rated outboard gear box on 8' model
- \* 10 ga. Steel round back deck with 7" high sides on 7' model
- \* 12 ga. Steel deck with 7" high sides on 8' model
- \* Flat bar and formed channel deck reinforcing
- \* 2" cutting capacity
- \* Optional safety guard chains available

MODEL	MAXIMUM PTO HP	CUTTING WIDTH	WEIGHT	LIST PRICE
1507	90 HP	84" / 7'	1305 lbs.	\$3109
1708	90 HP	96" / 8'	1365 lbs.	\$4459

The manufacturer highly recommends the use of optional safety guard chains.

**OPTIONS:**

MODEL	DESCRIPTION	LIST PRICE
CG1507	84" / 7' Safety chain guard kit	\$595
CG1708	96" / 8' Safety chain guard kit	\$695

# ROTARY CUTTERS 600 SERIES HEAVY DUTY 3 Pt.



Model 684 shown with dual wheels

With over 50 years of innovative design and production, BROWN Mfg. has set the standard for heavy duty rotary cutters. The 600 series rotary cutter comes with a 145 HP rated gearbox, with limited 5 year warranty. Available in two sizes, 6' and 7' with a slip-clutch PTO Shaft, this heavy duty brush cutter is tough enough to cut heavy brush and trees up to 4" in diameter.

- \* Deck Construction, all welded 1/4" thick, steel plate
- \* 145 HP rated gearbox, 1:1.5 ratio
- \* Available in 540 RPM & 1000 RPM
- \* Cat. 8 - 4 Slip-clutch PTO shaft
- \* Laminated solid rubber tail wheels 5.00 x 8
- \* Available with single or dual tail wheel
- \* Cat. II clevis style with flex link 3 Pt. hitch
- \* 1-1/4"- 6' & 1"- 7' solid blade bar
- \* 5/8" x 6" Blades(Ultra-Kor tm)
- \* Replaceable slides 5/8" x 2 1/2"
- \* Reinforced rear deflector shield
- \* Standard front safety chain guards

MODEL	DESCRIPTION	WEIGHT	LIST PRICE
672HD	6' Brush Cutter 540 RPM Single tail wheel	1600 lbs	\$8929
672HD-1	6' Brush Cutter 1000 RPM Single tail wheel	1600 lbs	\$8929
672HD-D	6' Brush Cutter 540 RPM Dual tail wheel	1720 lbs	\$9495
672HD-D-1	6' Brush Cutter 1000 RPM Dual tail wheel	1720 lbs	\$9495
684	7' Brush Cutter 540 RPM Dual tail wheel	2200 lbs	\$10,199
684-1	7' Brush Cutter 1000 RPM Dual tail wheel	2200 lbs	\$10,199

# ROTARY CUTTER CHAIN MULCHER OFFSET

Fransgård



New from Fransgard, a 3 Pt. hitch, 5' offset rotary cutter, 540 RPM PTO with a unique cutting system consisting of four 3/8" x 30" long chains used as the cutting/mulching blades. This unit has the ability to cut or mulch material up to 4" in diameter, offset from the tractor. For cutting ditch banks, around ponds, fence lines etc.

- \* 540 RPM PTO
- \* PTO Shaft with overrunning clutch
- \* 5' cutting width
- \* Cutting capacity up to 4"
- \* Cutting chains 4 x 3/8" x 30" long, hardened
- \* Rear Safety Guard
- \* Adjustable hydraulic offset capabilities up to 47"
- \* Offset overload protection
- \* Cat II 3 Pt. hitch
- \* Triple banded v-belt with automatic belt tightner
- \* Requires two sets of hydraulic remotes
- \* Includes hydraulic hoses
- \* Minimum 45 HP required
- \* Range of cutting head movement (degrees) 35 down/90 up

MODEL	DESCRIPTION	WEIGHT	LIST PRICE
FKR150	5' PTO Offset Rotary Cutter	1797 lbs	\$16,695

# ROTARY CUTTER TREE CUTTER



The BROWN Mfg. 3 Pt. hitch Tree Cutter can give you the high performance and ability you expect from a machine of this quality. With either an open deck or the versatility of a folding deck unit you can cut and mulch trees, up to 8" diameter.

<b>Model Price</b>	<b>TCO-2505C</b> <b>\$10,229</b>	<b>TCO-2605C</b> <b>\$11,379</b>	<b>TCO-2625C</b> <b>\$12,659</b>	<b>TCF-2605</b> <b>\$12,785</b>	<b>TCF-2625</b> <b>\$14,225</b>
Model/RPM	Open Deck 540 RPM	Open Deck 540 RPM	Open Deck 540 RPM	Folding Deck 540 RPM	Folding Deck 540 RPM
<b>Model Price</b>	<b>TCO-2500C</b> <b>\$10,229</b>	<b>TCO-2600C</b> <b>\$11,379</b>	<b>TCO-2620C</b> <b>\$12,659</b>	<b>TCF-2600</b> <b>\$12,785</b>	<b>TCF-2620</b> <b>\$14,225</b>
Model/RPM	Open Deck 1000 RPM	Open Deck 1000 RPM	Open Deck 1000 RPM	Folding Deck 1000 RPM	Folding Deck 1000 RPM
<b>Cutting Width</b>	<b>60"</b>	<b>72"</b>	<b>72"</b>	<b>72"</b>	<b>72"</b>
<b>PTO</b>	<b>Over-running 4 Disc Slip Clutch PTO</b>				
<b>Frame</b>	<b>3 x 3 x 1/4" Tubing</b>	<b>3 x 3 x 1/4" Tubing</b>	<b>3 x 3 x 1/4" Tubing</b>	<b>3 x 3 x 1/4" Tubing</b>	<b>3 x 3 x 1/4" Tubing</b>
<b>Deck</b>	<b>3/16" Plate Reinforced</b>	<b>Reinforced Double 1/4" plate to 1/2" total</b>	<b>Reinforced Double 1/4" plate to 1/2" total</b>	<b>Reinforced Double 1/4" plate to 1/2" total</b>	<b>Reinforced Double 1/4" plate to 1/2" total</b>
<b>Weight</b>	<b>1,705 Lbs.</b>	<b>2,240 Lbs.</b>	<b>2,455 Lbs.</b>	<b>2,565 Lbs.</b>	<b>2,710 Lbs.</b>
<b>Rear Guard / Rear Deck</b>	<b>2 Coil springs, collapsible push bar type</b>	<b>2 Coil springs, collapsible push bar type</b>	<b>2 Coil springs, collapsible push bar type</b>	<b>Twin folding Hydraulic rear sec- tion</b>	<b>Twin folding Hydraulic rear sec- tion</b>
<b>Gear Box</b>	<b>145 HP</b>	<b>145 HP</b>	<b>165 HP</b>	<b>145 HP</b>	<b>165 HP</b>
<b>H.P</b>	<b>50 to 90</b>	<b>60 to 90</b>	<b>70 to 100</b>	<b>70 to 90</b>	<b>80 to 100</b>
<b>Material Size</b>	<b>6" Maximum</b>	<b>6" Maximum</b>	<b>8" Maximum</b>	<b>6" Maximum</b>	<b>8" Maximum</b>

# SICKLE BAR MOWERS



AGRICULTURAL  
MACHINERY



For tractors from 20 to 75 HP, the double action sickle bar mowers are Category I/II 3 Pt. hitch mounted. Units come with a safety breakaway bar that helps protect the cutter from obstructions in the field. Units come with a second sickle cutting knife. All units are equipped with a hydraulic lift on the cutter bar, single acting, tractor must be equipped with rear remote hydraulic couplers.

- \* HP Requirements: 20-75, 540 RPM
- \* Double action sickle bar
- \* Adjustable 3 Pt. hitch
- \* Safety release
- \* 3 Pt. linkage, Cat. 1 and 2
- \* Extra blade and chain with hook
- \* Transport blade protection
- \* Hydraulic lift system
- \* Heavy duty shielded PTO shaft (1-3/8" ASAE Cat. 4)
- \* Cuts at 45° up and 45° down
- \* Belt Driven
- \* Hydraulic Lift Cutter bar
- \* Tractor counter weight maybe required

MODEL	CUTTING WIDTH	LIFT TYPE	WEIGHT	LIST PRICE
SBM006	6' / 72"	Hydraulic	576 lbs.	\$5369
SBM007	7' / 84"	Hydraulic	600 lbs.	\$5669
SBM008	8' / 96"	Hydraulic	648 lbs.	\$6199
SBM009	9' / 108"	Hydraulic	731 lbs.	\$6849

Weights indicated are base machine weight, not shipping weight

# STRING TRIMMER

## Engine Driven

## Walk Behind



The SWISHER walk-behind string trimmer is an ideal back-saving alternative to heavy hand-held gas trimmers. The trimmer's extra wide 22" cutting swath rivals that of most lawnmowers, while it's user-friendly design offers unsurpassed precision trimming performance. The trimmer features 13.75" wheels for plenty of clearance and smooth rolling over rough terrain. The trimmer line is easily replaced without the use of tools

- \* 6.75 HP 190CC Briggs & Stratton Engine
- \* Offset fixed left
- \* Two 13.75" solid tires
- \* Trimmer head (4).155" strings
- \* .25 US gallon fuel capacity
- \* Trimmer head disengages with engine running

MODEL	DESCRIPTION	WEIGHT	LIST PRICE
STS67522BS	6.75 HP, walk behind String trimmer	74 lbs.	\$639

### OPTIONS:

MODEL	DESCRIPTION	LIST PRICE
P3618	36 pack, 18" .155 trimmer line	\$15



# FINISHING MOWER

## Engine Driven

### Pull Type



SWISHER finish cut Trailmower is perfect for any large area of grass to be mowed. Backed by the power of 60 + years of design experience, this mower is designed to dramatically reduce mowing time. The SWISHER Trailmower easily attaches to your ATV, UTV or lawn tractor to cut large lawns or park areas. This trailmower is powered by a 14.5 HP Briggs & Stratton engine and gives your lawn a manicured look. A 60" side-discharge fabricated cutting deck cuts a wide swath and spreads the grass out to avoid choking. The true floating deck reduces scalping for professional mowing results, even on tricky terrain. This mower is equipped with a 12 volt key starter (12V battery not included). A universal articulating hitch attaches to any pin hitch system and lets the mower maneuver easily behind the towing vehicle.

- \* 14.5 HP Briggs & Stratton Engine
- \* Offset hitch, left/right/center articulating
- \* Tires four 13x5x6 pneumatic tires
- \* Three finishing cut blades
- \* Side discharge fabricated mower deck
- \* Cutting Height 1.5" – 5.5" Manual 3 point full floating deck
- \* Includes front mount anti-scalping rollers
- \* 2.5 US gallon fuel capacity
- \* Clevis/pin type hitch
- \* 12V electric start
- \* Manual PTO Clutch
- \* 12V battery not included

MODEL	DESCRIPTION	WEIGHT	LIST PRICE
FC14560BS	60", 14.5 HP B&S engine Electric start	353 lbs.	\$3179

# FINISHING MOWERS

## Engine Driven



Gas powered mowers for lawn tractors and ATV's. This three spindle finishing mower comes complete with:

- \* 11.5 HP Briggs & Stratton I/C engine with centrifugal clutch
- \* Rear discharge
- \* Spindle shafts greased from the top for easy service
- \* Two front swivel tires and two rear non-swivel tires
- \* Cutting height: 1" to 4"
- \* Cat. 1 ball hitch
- \* Semi pneumatic tires
- \* 10 gauge reinforced mower deck
- \* Heavy duty reinforced belt (BX)
- \* Heavy duty, one piece, balanced steel pulleys
- \* Safety kill switch
- \* High blade tip speed

MODEL	CUTTING WIDTH	BLADE TIP SPEED (FT/MIN)	WEIGHT	LIST PRICE
C30CE5H	60"	14,173	388 lbs.	\$3575

# FINISHING MOWERS

## 3 Pt. Rear Discharge



These mowers are ideal for use with 540 RPM 15 – 30 HP tractors with Cat. I 3 Pt. hitch. These three blade finishing mowers with a rotor speed of 2630 RPM are available in 5' and 6' cutting width. These mowers are perfect for maintaining any type of grassy area, from your home estate to golf courses and park areas. These mowers are designed to easily adjust the cutting height, which can be changed by simply adjusting the spacers on the wheel yoke.

- \* Rear Discharge with rear safety chains
- \* 3" x 8" Solid Rubber Wheel/Tires
- \* Floating Style Cat. I 3 Pt. Hitch
- \* 540 RPM PTO
- \* Powder Coat Paint
- \* Deck thickness 5' - 12ga.  
6' - 10ga.
- \* 3 Blades with Greaseable Spindles
- \* Blade tip speed 5' - 14,961 ft/min.  
6' - 13,976 ft/min
- \* Double V-Belt Drive
- \* Cutting Height Adjustment 1-1/2" to 4-1/2"

MODEL	DESCRIPTION	WEIGHT	LIST PRICE
BFM105	5' / 60" cutting width mower	386 lbs.	\$1459
BFM106	6' / 72" cutting width mower	508 lbs.	\$1829

# FINISHING MOWERS

## C30 Series

### Rear Discharge



Optional front anti-scalping roller

For tractors 16 to 30 HP, 540 RPM, Category 1, 3 Pt. hitch. Rear discharge, three spindle grooming mower.

- \* Highly engineered & rugged gearbox with cooling fins
- \* Front and rear tractor mounting
- \* Four swivel 9" x 3.5" (4 ply with tubes) pneumatic tires
- \* Floating 3 Pt. linkage, Cat. 1
- \* 11 gauge reinforced mower deck
- \* 1" to 4" cutting height
- \* Spindle shafts greased from the top for easy service
- \* Heavy duty reinforced belt (BX)
- \* Heavy duty, one piece, balanced steel pulleys
- \* High blade tip speed
- \* Precise blade overlap

MODEL	CUTTING WIDTH	BLADE TIP SPEED (FT/MIN)	WEIGHT	LIST PRICE
C30RD5A	60"	14,763	364 lbs.	\$2899
C30RD6A	72"	14,566	429 lbs.	\$3159

#### OPTIONS:

MODEL	DESCRIPTION	LIST PRICE
001-600	Front antiscalping roller	\$135
005-600	Mulching kit for model C30RD5	\$409
006-600	Mulching kit for model C30RD6	\$435

# FINISHING MOWERS

## C50 Series

### Rear Discharge



Optional front anti-scalping roller

C50RD7A Shown



Floating Linkage on 5' & 6'

Ideal for tractors from 20 to 50 HP. Category 1, 3 Pt. hitch, 540 RPM. These 3 spindle **BEFCO** rear discharge mowers come complete with:

- \* 1" to 5" cutting height
- \* Highly engineered & rugged gear box with cooling fins
- \* Heavy duty shielded PTO shaft (1-3/8" ASAE Cat. 3)
- \* Four height control bearingwheels
- \* Floating 3 Pt. linkage, Cat. 1
- \* Spindle shafts greased from the top for easy service
- \* Heavy duty, one piece, balanced steel pulleys
- \* Two heavy duty reinforced belts (SPBX)
- \* High blade tip speed
- \* Pneumatic tires 11" x 4" (4 ply with tube)
- \* 8 gauge reinforced mower deck
- \* Four castor wheels
- \* C50RD5 & C50RD6 mowers include standard CAT. I lower lift pins
- \* C50RD7 mower includes CAT. I clevis type lower lift pins

MODEL	CUTTING WIDTH	BLADE TIP SPEED (FT/MIN)	WEIGHT	LIST PRICE
C50RD5A	60"	16,929	534 lbs.	\$3820
C50RD6A	72"	16,732	584 lbs.	\$4045
C50RD7A	84"	16,338	674 lbs.	\$4735

#### OPTIONS:

MODEL	DESCRIPTION	LIST PRICE
009-9915	Front anti-scalping roller for 5' and 6' mowers, standard on 7' mower	\$155
009-9815	Professional front anti-scalping roller	\$219
005-700	Mulching kit for model C50RD5	\$420
006-700	Mulching kit for model C50RD6	\$479
007-700	Mulching kit for model C50RD7	\$559

# FINISHING MOWERS

## C70 Series

### Rear Discharge



For tractors from 30 to 70 HP, Category 1, 3 Pt. hitch, 540 RPM. These 3 spindle **BEFCO** rear discharge mowers come complete with:

- \* Highly engineered & rugged gearbox with cooling fins
- \* Cutting height: 1.3" to 5.3"
- \* Front and rear tractor mounting
- \* Four heavy duty bearing wheels
- \* Floating 3 Pt. linkage, Cat. 1
- \* Two heavy duty reinforced belts (CX)
- \* Heavy duty shielded PTO shaft (1-3/8" ASAE Cat. 4)
- \* Six free swinging kick back blades
- \* Spindle shafts greased from the top for easy service
- \* Heavy duty, one piece, balanced steel pulleys
- \* High blade tip speed
- \* Pneumatic tires 13" x 6.5" 4 ply with tubes
- \* Front anti-scalping roller
- \* 8 gauge reinforced mower deck
- \* Optional hard rubber, semi-pneumatic tires available

MODEL	CUTTING WIDTH	BLADE TIP SPEED (FT/MIN)	WEIGHT	LIST PRICE
C70090A	90"	13,976	1137 lbs.	\$7525
C70110A	110"	14,960	1290 lbs.	\$8869

# FLEX MOWERS

## 3 Pt. Hitch



- \* HP Requirements: 25-60, 540 RPM
- \* 1" to 4" cutting height
- \* Available in rear 3 Pt. or front 3 Pt. hitch mounting, specify at time of order
- \* Single action hydraulic folding wings
- \* Cat. 1, 3 Pt. hitch
- \* Heavy duty reinforced belts (BX)
- \* Driveline with slip clutch (1-3/8" ASAE Cat. 6)
- \* Three completely independent free floating mower decks
- \* Transport width 7'10" max.
- \* Transport safety locks
- \* Unique double pivot floating linkage
- \* Front anti-scalping roller standard
- \* 4 pneumatic tires with bearings per mower deck
- \* 9" x 3.5" pneumatic tires (4 ply with tubes)
- \* Includes detachable wheeled transport frame

MODEL	CUTTING WIDTH	UNIT MAKEUP	WEIGHT	LIST PRICE
112EZFA	12 ft	(2) 4' & (1) 5'	1870 lbs.	\$17,269
115EZFA	15 ft	(2) 5' & (1) 6'	2112 lbs.	\$19,649

### OPTIONS:

MODELS	DESCRIPTION	LIST PRICE
009-9592	Mulching kit for model 112EZF (3 units)	\$1175
009-9826	Mulching kit for model 115EZF (3 units)	\$1295
009-9593	Hydraulic unlocking system	\$669

# FLEX MOWERS

## Pull Type Cyclone Flex



For technical specifications on individual mower decks  
see page 21 (C50 Mowers)

- \* HP Requirements: 25-60, 540 RPM
- \* Heavy duty transport frame
- \* Cutting height: 1" to 5"
- \* Pull type mower with high flotation transport tires (20.5" x 8"x10")
- \* Single action hydraulic folding wing system for easy transport and storage
- \* Transport width 7' 10" max.
- \* CV driveline with slip clutch (1-3/8" ASAE Cat. 6)
- \* Deck overlap adjustment 6"
- \* Three front anti-scalping rollers standard
- \* Safety chain shield standard
- \* Remote safety locks for transporting
- \* Each mower deck has four 11" x 4" (4 ply pneumatic tires & tubes)
- \* Optional hard rubber, semi-pneumatic tire for mower decks available. Specify at time of order

MODEL	CUTTING WIDTH	UNIT MAKE UP	WEIGHT	LIST PRICE
312FLXA	12'	(2) FX4 & (1) FX5	2694 lbs.	\$20,999
315FLXA	15'	(2) FX5 & (1) FX6	2826 lbs.	\$22,965
317FLXA	17'	(3) FX6	2947 lbs.	\$23,845

### OPTIONS:

MODEL	DESCRIPTION	LIST PRICE
009-9556	Mulching kit for model 312-FLX (3 units)	\$1245
009-9557	Mulching kit for model 315-FLX (3 units)	\$1365
009-9558	Mulching kit for model 317-FLX (3 units)	\$1485
009-9552	Hydraulic unlocking system	\$669
009-9597	Floating hitch	\$309



# FLEX MOWERS

## Super-Flex Pull Type



For technical specifications on individual mower decks  
see page 21 (C50 Mowers)

- \* HP Requirements: 35-80, 540 RPM
- \* Extra heavy duty transport frame
- \* 1" to 5" cutting height
- \* Pull type mower with high flotation transport tires (23" x 10.5" x 12")
- \* Single action hydraulic folding wing system for easy transport and storage
- \* Three front anti-scalping rollers standard
- \* CV driveline with slip clutch (1-3/8" ASAE Cat. 6)
- \* Deck overlap adjustment 6"
- \* Safety chain shield standard
- \* Remote safety locks for transporting
- \* Each mower deck has four 13" x 6.5" (4 ply air tires with tubes)

MODEL	CUTTING WIDTH	UNIT MAKEUP	WEIGHT	LIST PRICE
412SFLA	12'	(2) SF4 & (1) SF5	3090 lbs.	\$24,699
415SFLA	15'	(2) SF5 & (1) SF6	3267 lbs.	\$25,975
417SFLA	17'	(3) SF6	3438 lbs.	\$28,159
420SFLA	20'	(3) SF7	3747 lbs.	\$31,785

### OPTIONS:

MODEL	DESCRIPTION	LIST PRICE
009-9556	Mulching kit for model 412-SFL (3 units)	\$1245
009-9557	Mulching kit for model 415-SFL (3 units)	\$1365
009-9558	Mulching kit for model 417-SFL (3 units)	\$1485
009-9559	Mulching kit for model 420-SFL (3 units)	\$1735
009-9552	Hydraulic unlocking system	\$669
009-9597	Floating hitch	\$309

Weights indicated are base machine weight, not shipping weight

# FLAIL MOWERS

## H40 Series, Hurricane



For tractors from 15 to 40 HP, Category 1, 3 Pt. hitch, 540 RPM. Flail mowers come complete with:

- \* 1" to 5" cutting height
- \* Two heavy duty reinforced notched belts (SPBX)
- \* Highly engineered & rugged gearbox with cooling fins
- \* High blade tip speed
- \* Adjustable cutting height roller
- \* Perfectly balanced rotor
- \* Two pc. regular cut knives - Optional
- \* Two pc. fine cut knives - Standard
- \* Clockwise rotation is standard
- \* Offset from center: 3" on H40-048  
8.5" on H40-060  
6.5" on H40-072
- \* Front rubber safety shielding
- \* Optional hammer type blades available

MODEL	CUTTING WIDTH	STANDARD # BLADES	OFFSET	WEIGHT	LIST PRICE
H40-048	48"	48	3"	418 lbs.	\$3745
H40-060	60"	64	8.5"	456 lbs.	\$3999
H40-072	72"	76	6.5"	528 lbs.	\$4525

### OPTIONS:

MODEL	DESCRIPTION	LIST PRICE
009-9507	Side skid shoes (pair)	\$129
009-9200	*Hammer type blades for model H40-048	\$305
009-9201	*Hammer type blades for model H40-060	\$400
009-9202	*Hammer type blades for model H40-072	\$480

\*Specify at time of order

# FLAIL MOWERS

## H70 Series, Hurricane



For tractors from 30 to 70 HP, Category 1, 3 Pt. hitch, 540 RPM. Flail mowers come complete with:

- \* 3/4" to 6" cutting height
- \* Front & rear tractor mounting
- \* Adjustable cutting height roller with scraper
- \* High blade tip speed
- \* Heavy duty shielded PTO shaft with over running clutch (1-3/8" ASAE Cat. 4).
- \* Highly engineered & rugged gearbox
- \* Electronically balanced rotor
- \* Two heavy duty reinforced notched belts (CX)
- \* Semi-automatic belt tensioner
- \* Floating top link
- \* Sealed rotor bearings
- \* Fine cut (2 Pc) knives-standard
- \* Regular cut (2 pc reversible Y) knives - Optional
- \* Forward rotor rotation is standard
- \* Reverse rotor rotation is optional (Extra)
- \* Rotor RPM: 2080
- \* Blade tip speed (ft/min): 8464
- \* Optional hammer type blades available

MODEL	CUTTING WIDTH	OVERALL WIDTH	# BLADES	WEIGHT	LIST PRICE
H70-060	60"	71"	64	869 lbs.	\$7489
H70-072	72"	85"	80	955 lbs.	\$7999
H70-088	88"	99"	96	1078 lbs.	\$8529

### OPTIONS:

MODEL	DESCRIPTION	LIST PRICE
009-9691	Gauge wheels with laminated tires (pair)	\$1115
009-9201	*Hammer type blades for model H70-060	\$400
009-9203	*Hammer type blades for model H70-072	\$495
009-9204	*Hammer type blades for model H70-088	\$590

\*Specify at time of order

Weights indicated are base machine weight, not shipping weight

# FLAIL MOWERS

## H80 Series

### Hurricane Commercial

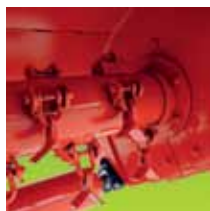

Ideal for tractors from 40 to 80 HP, Category 1 and 2, 3 Pt. hitch, 540 RPM. Flail mowers come complete with:

- \* 3/4" to 6" cutting height
- \* Frame thickness: 8 gauge
- \* Side plates thickness: 5/16"
- \* Rotor diameter: 6"
- \* Rotor wall thickness: 5/16" (72") & 3/8" (88" and 100")
- \* Regular cut (2 pc. reversible Y) blades - standard
- \* Fine cut (2 pc.) blades - optional
- \* High blade tip speed
- \* Adjustable cutting height roller with scraper
- \* Highly engineered gearbox
- \* Front & rear tractor mounting
- \* Electronically balanced rotor
- \* Heavy duty, one piece, balanced steel pulleys
- \* Two heavy duty reinforced notched belts (CX)
- \* 3 Pt. linkage, Cat. 1 and 2
- \* Floating top link
- \* Forward rotor rotation is standard
- \* Reverse rotor rotation is optional (Extra)
- \* Replaceable skid shoes
- \* Semi-automatic belt tensioner
- \* Sealed 2" rotor bearings
- \* Driveline with over-running clutch (1-3/8" ASAE Cat. 6)
- \* Rotor RPM: 1873
- \* Blade tip speed (ft/min): 8268
- \* Optional hammer type blades available

MODEL	CUTTING WIDTH	OVERALL WIDTH	# BLADES	WEIGHT	LIST PRICE
H80-072	72"	85"	80	1153 lbs.	\$10,099
H80-088	88"	99"	96	1296 lbs.	\$11,119
H80-100	100"	110"	104	1486 lbs.	\$12,299

#### OPTIONS:

MODEL	DESCRIPTION	LIST PRICE
009-9701	Gauge wheels with laminated tires (pair)	\$1355
009-9203	*Hammer type blades for model H80-072	\$495
009-9204	*Hammer type blades for model H80-088	\$590
009-9205	*Hammer type blades for model H80-100	\$639

\*Specify at time of order

# FLAIL SHREDDER

## Destroyer Series



New from BEFCO a heavy duty Flail shredder, with hydraulic side shift. Available in three sizes 60", 72", and 88". Comes standard with Cat. I & II rear mounted 3 Pt. hitch. Heavy duty hammer type blades that can shred material up to 2" thickness. Horse power recommended 40- 90.

- \* Cat. I & II Rear Mount 3 Pt. Hitch
- \* 540 RPM PTO with Overrunning Clutch is standard
- \* 4 Belt Driven Transmission, with Manual Belt Tensioner
- \* Hydraulic Side Shift (Offset) 12" on 60" model & 16" on 72" & 88" models
- \* Heavy Duty Hammer Type blades
- \* Rotor Diameter 133mm(5-1/4"), 8mm(1/4") thick tube
- \* Height adjustment via rear roller, with scraper
- \* Rear Roller Diameter 168mm(6-1/2"), 4.5mm(3/16") thick tube

MODEL	D90-060	D90-072	D90-088
WORKING WIDTH	60"	72"	88"
OVERALL WIDTH	69"	81"	96"
WEIGHT	1257 lbs.	1345 lbs.	1491 lbs.
# OF HAMMERS	16	20	24
HYD SIDE SHIFT	12"	16"	16"
CUTTING CAPACITY	2"	2"	2"
PRICE	\$9555	\$10,130	\$10,659

### OPTIONS:

MODEL	DESCRIPTION	LIST PRICE
009-9968	*Dual PTO gear box and front mount 3 Pt. hitch (Factory Installed)	\$409
009-9969	Skid shoes (pair)	\$265

\*Specify at time of order

Weights indicated are base machine weight, not shipping weight

# ROTARY TILLER

## Engine Driven - Pull Type

**Agri-Fab**  
Lawn Care Made Easy



The Agri-Fab Multi-Fit tow behind rotary tiller comes with a 6.5 HP B&S Intek engine and has a 36" tilling width with conveniently located controls. Quickly prepare the perfect planting bed with minimal effort. Can be used with any ATV or garden tractor above 12 HP.

- \* 205cc B&S Intek Engine
- \* Recoil start
- \* 36" Tilling width
- \* Forward rotating tines
- \* Six double edge 11" diameter heavy duty tines
- \* Tilling depth adjustable from 1-1/2" to 5-1/2"

MODEL	DESCRIPTION	WEIGHT	LIST PRICE
450308	Pull type - 36"	229 lbs.	\$1859

# ROTARY TILLERS

## Manual Side-Shift



The **ROTOMECH** tiller is a rugged machine with an extremely simple and functional side shift at no additional charge. Ideal for tractors ranging from 20 to 40 HP. Tillers come complete with:

- \* Highly engineered and rugged gearbox
- \* Four knives per flange
- \* Solid rotor shaft
- \* Heavy duty tiller blades
- \* Shielded shear pin PTO
- \* Cat I 3 Pt. hitch
- \* Reinforced lateral 80 ASA chain drive transmission in oil bath
- \* Adjustable skids for depth control
- \* Exchangeable sprockets for 2 rotor speeds, 231/375 RPM
- \* Working Depth up to 7 1/4"

	WORKING					LIST
MODEL	WIDTH	OFFSET	# FLANGES	# KNIVES	WEIGHT	PRICE
142-231	42"	10"	5	20	373 lbs.	\$2569
150-231	50"	14"	6	24	407 lbs.	\$2659
158-231	58"	18"	7	28	452 lbs.	\$2795
166-231	66"	22"	8	32	492 lbs.	\$2999

# ROTARY TILLERS

## T30 Series

### Manual Side-Shift



For tractors from 18 to 30 HP. Category 1, 3 Pt. hitch, 540 RPM PTO. T30 series tillers come complete with:

- \* HP Requirements: 16-30, 540 RPM
- \* Highly engineered and rugged gearbox with cooling fins
- \* Four blades per flange
- \* High carbon solid steel round rotor shaft allows for a deeper working depth
- \* Heavy duty full size blades
- \* Heavy duty shielded PTO shaft with shear pin coupling (1-3/8" ASAE Cat. 2)
- \* # 60 chain drive
- \* Adjustable side skids for working depth control

MODEL	WORKING		# FLANGES	# BLADES	WEIGHT	LIST PRICE
	WIDTH	OFFSET				
T30-134	34"	6"	4	16	297 lbs.	\$2495
T30-142	42"	10"	5	20	341 lbs.	\$2579
T30-150	50"	14"	6	24	374 lbs.	\$2725

#### OPTIONS:

MODEL	DESCRIPTION	LIST PRICE
009-9538	Cat. 0, 3 Pt hitch (Specify at time of ORDER)	\$195

Specify at time of order



# ROTARY TILLERS

## T40 Series

### Manual Side-Shift



For tractors up to 40 HP. Category 1, 3 Pt. hitch, 540 RPM PTO. T40 series tillers come complete with:

- \* Highly engineered and rugged gearbox
- \* Four blades per flange
- \* Solid steel rotor shaft
- \* Adjustable side skirts for working depth control
- \* Wear protection on chain case
- \* Heavy duty full size blades
- \* Heavy duty shielded PTO shaft with slip clutch safety (1-3/8" ASAE Cat. 3)
- \* # 80 chain drive with exchangeable sprockets for 2 rotor speeds, 231/375 RPM

MODEL	WORKING			# FLANGES	# BLADES	WEIGHT	LIST PRICE
	WIDTH	OFFSET					
T40-242	42"	10"		5	20	373 lbs.	\$3195
T40-250	50"	14"		6	24	417 lbs.	\$3325
T40-258	58"	18"		7	28	461 lbs.	\$3439
T40-266	66"	22"		8	32	530 lbs.	\$3775

Weights indicated are base machine weight, not shipping weight

# ROTARY TILLERS

## T50 Series

### Manual Side-Shift



For tractors up to 50 HP. Category 1, 3 Pt. hitch, 540 RPM PTO. T50 series tillers come complete with:

- \* HP Requirements: 25-50, 540 RPM
- \* Highly engineered and rugged gearbox
- \* Six blades per flange for greater stability & finer soil pulverization
- \* Solid steel rotor shaft
- \* Heavy duty shielded PTO with shaft with slip clutch safety (1-3/8" ASAE Cat. 4)
- \* Heavy duty full size tiller blades
- \* Wear protection on chain case
- \* Adjustable side skirts for working depth control
- \* Lateral #100 Roller Chain drive transmission in oil bath
- \* Exchangeable sprockets for two rotor speeds 226/383 RPM
- \* Max. working depth 8-3/8"

	WORKING					LIST
MODEL	WIDTH	OFFSET	# FLANGES	# BLADES	WEIGHT	PRICE
T50-350	50"	14"	6	36	481 lbs.	\$3995
T50-358	58"	18"	7	42	528 lbs.	\$4129
T50-366	66"	22"	8	48	575 lbs.	\$4339

# ROTARY TILLERS

## T60 Series

### Manual Side-Shift



For tractors up to 60 HP. Category 1, 3 Pt. hitch, 540 RPM PTO. T60 series tillers come complete with:

- \* HP Requirements: 30-60, 540 RPM
- \* Highly engineered and rugged gearbox
- \* Six blades per flange for greater stability & finer soil pulverization
- \* Solid steel rotor shaft
- \* Heavy duty full size tiller blades
- \* Wear protection on chain case
- \* Adjustable side skids for working depth control
- \* # 100 chain drive in oil bath
- \* Heavy duty shielded PTO shaft with slip clutch safety (1-3/8" ASAE Cat.6)
- \* Max. working depth 8-3/8"

MODEL	WORKING WIDTH	OFFSET	# FLANGES	# BLADES	WEIGHT	LIST PRICE
T60-366	66"	22"	8	48	740 lbs.	\$5425
T60-374	74"	26"	9	54	798 lbs.	\$5645

Weights indicated are base machine weight, not shipping weight

# ROTARY TILLERS

## T70 Series



For tractors up to 70 HP. Category 1, 3 Pt. hitch, 540 RPM PTO. T70 series tillers come complete with:

- \* HP Requirements: 30-70, 540 RPM
- \* Heavy duty reinforced frame
- \* Six blades per flange for greater stability & finer soil pulverization
- \* Max working depth 8-3/4"
- \* Wear protection on chain case
- \* Heavy duty shielded PTO shaft with slip clutch safety (1-3/8" ASAE Cat.6)
- \* Adjustable side skids for working depth control
- \* Flanged rotor shaft for easy removal & service
- \* Solid steel rotor shaft
- \* Heavy duty gearbox
- \* # 100 chain drive transmission in oil bath

MODEL	WORKING WIDTH	OFFSET	# FLANGES	# BLADES	WEIGHT	LIST PRICE
T70-382	82"	22"	10	60	879 lbs.	\$5909

# SOIL-PULVERIZERS



- \* 3/8" steel spikes fully welded in a timed scroll pattern
- \* 10" frame beam (Standard)
- \* 12" frame beam (Heavy Duty)
- \* Two rows heavy duty reversible heat treated scarifier shanks
- \* 5-9/16" dia. spiked roller tube (Standard)
- \* 6-5/8" dia. spiked roller tube (Heavy Duty)
- \* Complete with two 160 lbs. compression roller springs
- \* Optional 2nd spiked roller available with 2-80 lb. compression
- \* Reversible heat treated 1/2" x 2" shanks
- \* 3 Pt. linkage, Cat. 1
- \* Self aligning 1" bearing on roller
- \* Formed plate "A" frame
- \* Shank spacing 2-13/16"

## STANDARD

MODEL	WORKING		# SHANKS	# ROLLER	
	WIDTH	WEIGHT		SPIKES	LIST PRICE
BPL048	48"	496 lbs.	17	70	\$2135
BPL060	60"	652 lbs.	21	88	\$2279
BPL072	72"	679 lbs.	25	106	\$2515

## HEAVY DUTY

MODEL	WORKING		# SHANKS	# ROLLER	
	WIDTH	WEIGHT		SPIKES	LIST PRICE
BPL284	84"	875 lbs.	29	124	\$3399

### OPTIONS:

Add-on double roller includes bracket & bearings

MODEL	DESCRIPTION	LIST PRICE
009-9887	48" x 5" dia. for BPL048	\$600
009-9636	60" x 5" dia. for BPL060	\$700
009-9637	72" x 5" dia. for BPL072	\$850
009-9647	84" x 5-9/16" dia. for BLP284	\$1069

Weights indicated are base machine weight, not shipping weight

# AERATOR / OVERSEEDER

## Green-Rite



For tractors from 25 to 70 HP. Category 1, 3 Pt. hitch. 540 RPM PTO. **BEFCO** Green-Rite Overseeders/Primary seeders come complete with:

- \* **HP Requirements: 25-70, 540 RPM**
- \* **Series T40 rotary tiller base machine on 50", 58", 66" and T70 on 82"**
- \* **Special 2.8" flange spacing on rotor for aerating with 3 knives per flange on GRT250, GRT258 & GRT266**
- \* **4 knives per flange on GRT288**
- \* **Straight aerator knives**
- \* **Seed covering/dethatching adjustable tickler tines**
- \* **Seed hopper with metering cups**
- \* **Ground drive system for seed hoppers**
- \* **Corrugated depth control roller made with low weight nylon/fiberglass roller rings**
- \* **Heavy duty shielded PTO shaft with slip clutch safety**

MODEL	WORKING WIDTH	HOPPER CAP. CU. FT.	# FLANGES	# BLADES	WEIGHT	LIST PRICE
GRT250	50"	4.60	15	43	910 lbs.	\$10,165
GRT258	58"	5.30	18	52	998 lbs.	\$10,459
GRT266	66"	6	21	61	1170 lbs.	\$11,719
GRT282	82"	7.6	26	104	1500 lbs.	\$15,100

**NOTE:** Units may utilize gauge wheels or a gauge roller for blade depth control, but not both.

### OPTIONS:

MODEL	DESCRIPTION	LIST PRICE
009-9875	Gauge wheels for all models	\$469
009-9648	Front roller for GRT-250	\$745
009-9516	Front roller for GRT-258	\$785
009-9563	Front roller for GRT-266	\$849
009-9566	Front roller for GRT-282	\$919
009-9649	Tiller rotor for GRT-250	\$735
009-9517	Tiller rotor for GRT-258	\$829
009-9564	Tiller rotor for GRT-266	\$925
009-9567	Tiller rotor for GRT-282	\$1715
009-9650	Rear roller scraper for GRT-250	\$259
009-9539	Rear roller scraper for GRT-258	\$295
009-9565	Rear roller scraper for GRT-266	\$409
009-9568	Rear roller scraper for GRT-282	\$469

# SEEDER/OVERSEEDER SEED-RITE



The BEFCO Seed-Rite is a primary full width seeder / overseeder. 74" working width, with a ground drive system for seed hopper. Steel seed box comes with a steel shaft agitator with ten high precision metering seed cups, with a wide range of calibration settings per acre. Two nylon/fiberglass corrugated rollers 9-1/2" in diameter the working width of seeder compact seed into soil. Unit can also be used as an overseeder for seeding existing lawns, parks etc.

- \* **Cat. I, 3 Pt. Hitch (quick hitch compatible)**
- \* **Parking stands**
- \* **74" seeding width**
- \* **80" overall width**
- \* **Heavy duty frame**
- \* **Heavy duty seed box lid with seed splash guard**
- \* **Seed box capacity 7 cu.ft.(5-1/2 Bu.)**
- \* **Seed box agitator**
- \* **10 high precision metering seed cups**
- \* **Wind guarded seed drop**
- \* **Two 9-1/2" diameter nylon/fiberglass corrugated rollers**
- \* **Greaseable roller bearings**
- \* **Two spring tine track removers**

MODEL	DESCRIPTION	WEIGHT (LBS.)	LIST PRICE
SRT074	74" Seed-Rite Seeder/Overseeder	990 lbs.	\$6785

## OPTIONS:

MODEL	DESCRIPTION	LIST PRICE
009-9930	Rear Expanded Roller Frame with Adjustable Tickle Tines for Seed Covering & De-thatching	\$675

# SNOW PLOW GARDEN TRACTOR & ATV

**Agri-Fab**  
Lawn Care Made Easy™



The patented NORDIC PLOW is a front mount blade made of high impact injected molded plastic and utilizes a “round” lower edge. This makes the NORDIC PLOW available for year round use. It glides easily over grass and paver bricks, so you can push dirt, sand or mulch as well as snow. The NORDIC PLOW adjusts/angles left or right with a release pin. It can also be raised or lowered manually, due to it's lightweight design with a hand strap. On ATV's you can utilize your front mounted winch for raising and lowering. The NORDIC PLOW includes universal fit mounting brackets to fit most traditional lawn & garden tractors (48" wide blade) and ATV's (48" wide blade)

- \* **Manufactured of high impact injected molded plastic**
- \* **Light weight**
- \* **48" wide blade for lawn & garden tractor includes universal lawn & garden tractor mounting brackets**
- \* **48" wide blade for ATV's includes universal ATV mounting brackets**
- \* **Angles left or right**
- \* **Raises & lowers by hand strap**

MODEL	DESCRIPTION	WEIGHT	LIST PRICE
450498	NORDIC 48" PLOW for standard lawn & garden	62 lbs.	\$575
450499	NORDIC 48" PLOW for standard ATV's	82 lbs.	\$699



# ATV ENGINE DRIVEN SNOWBLOWER



The Agri-Fab ATV dual stage snowblower has a 50" clearing width and comes with an 11HP Tecumseh Snow King engine that is engineered to start on the coldest of days. The large recoil starter handle allows for easy pulling with mitts or gloves on. The snowblower has a serrated auger with 5/16" shear pins and a large 12" diameter impeller, clutch engagement, directional controls and a conveniently located kill switch adjacent to the ATV's handlebars. Also includes a 12 volt electric lift and castor type transport wheels which take the weight of the snowblower off the front of ATV making turning a breeze.

- \* **50" clearing width**
- \* **21" Intake height**
- \* **11HP Tecumseh SNOW KING engine**
- \* **Recoil start**
- \* **1 Gallon fuel tank**
- \* **Rugged 5" poly discharge chute, adjustable up and down and rotates side to side 180°**
- \* **Includes mounting brackets to fit most ATV's**

MODEL	DESCRIPTION	WEIGHT (LBS.)	LIST PRICE
450418	2 Stage 50", 11HP Snowblower	380 lbs.	\$4109

# CORE AERATORS

## Heavy Duty



Shown with optional Steel Weight Tanks

- \* Spoon spacing 6-1/2"
- \* Working depth 4-1/2"
- \* Special high tensile steel shafts on the rotors
- \* Two bronze bushings per rotor
- \* 3/16" formed steel support panels
- \* All panels support rotors from all sides
- \* 1-1/4" rotor support shaft
- \* 3 Pt. linkage Cat. 1 and 2
- \* Cat. 1 and 2 quick hitch adaptable
- \* Eight spoons per hub
- \* All flanges are welded to rotors
- \* Rotor flange thickness 3/16"
- \* Three support stands
- \* 3/4" hardened steel spoons
- \* Front or rear tractor mounting

MODEL	WORKING OVERALL		WEIGHT	# SPOONS	ADDITIONAL	
	WIDTH	WIDTH			WEIGHT	LIST PRICE
BCA260	60"	65"	444 lbs.	80	19" x 21"	\$3375
BCA272	72"	78"	549 lbs.	96	25" x 21"	\$3735

### OPTIONS:

MODEL	DESCRIPTION	LIST PRICE
009-9734	Steel weight tank (model BCA260) 2 Required	\$400 ea
009-9735	Steel weight tank (model BCA272) 2 Required	\$430 ea

# REAR SCRAPER BLADES 3 Pt. 4100 Series

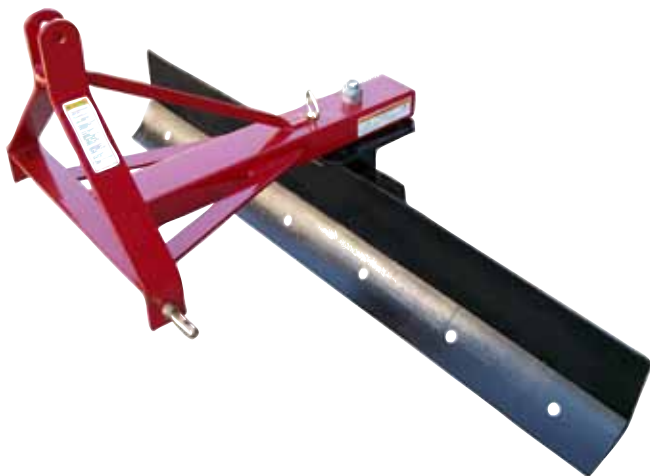

These affordable 3 Pt. rear scraper blades built by TITAN Implement are ideal attachment for tractors up to 45 HP. They have a reversible and a replaceable 6" cutting edge. They have a quick and easy left or right angle ability in forward or reverse position. Manufactured in U.S.A.

- \* Cat. I – 3 Pt. Hitch
- \* Rated for tractors 15 to 45 HP
- \* Available in 4', 5', 6' & 7' working widths
- \* Moldboard height 4' & 5' – 13" high , 6' & 7' – 14" high
- \* 6" reversible & replaceable cutting edge
- \* Angle adjustment 5 positions forward & reverse
- \* Quick hitch compatible

MODEL	WIDTH	WEIGHT	LIST PRICE
4104	4' / 48" working width	158 lbs.	\$349
4105	5' / 60" working width	179 lbs.	\$365
4106	6' / 72" working width	202 lbs.	\$419
4107	7' / 84" working width	223 lbs.	\$485

# REAR SCRAPER BLADES 3 Pt. 4400 Series



These affordable 3 Pt. rear scraper blades built by TITAN Implement are ideal attachment for tractors up to 65 HP. They have a reversible and a replaceable 6" cutting edge. They have a quick and easy left or right angle ability in forward or reverse position. They also offer offset and tilt adjustment. Manufactured in U.S.A.

- \* Cat. I – 3 Pt. Hitch
- \* Rated for tractors 35 to 65 HP
- \* Available in 5', 6' & 7' working widths
- \* Moldboard height 15.5" high
- \* 6" reversible & replaceable cutting edge
- \* Angle adjustment 5 positions forward & reverse
- \* Tilt adjustment 3 positions
- \* Offset adjustment 5 positions
- \* Quick hitch compatible

MODEL	WIDTH	WEIGHT	LIST PRICE
4405	5' / 60" working width	323 lbs.	\$709
4406	6' / 72" working width	340 lbs.	\$759
4407	7' / 84" working width	358 lbs.	\$839

# REAR SCRAPER BLADES

## Heavy Duty



These heavy duty rear scraper blades are designed to give you the quality, dependable performance that you require. They come with Category 1 and 2, 3 Pt. hitch for 35 to 85 HP. These units come equipped with quick tilt, angle and offset manual adjustments. A parking stand is standard.

- \* HP Requirements: 35-85
- \* Tilt adjustments: 15-16° right or left
- \* Offset adjustments: 15-30° right or left
- \* Moldboard thickness: 1/4"
- \* Moldboard height: 17"
- \* Reversible 1/2" x 6" cutting edge
- \* Angle adjustment 15° - 16° - 45° forward or reverse
- \* Cat. 1 and 2, 3 Pt. hitch

MODEL	WIDTH	WEIGHT	LIST PRICE
GB484	7'	576 lbs.	\$1745
GB496	8'	652 lbs.	\$1810

# SCRAPER BLADE HD HYDRAULIC



This 8 foot heavy duty rear scraper blade comes standard with one hydraulic cylinder for angling. It is built heavy to handle your roughest conditions. The blade can angle hydraulically, and offset and tilt manually. Blade cannot reverse to push.

- \* Cat II 3 Pt hitch
- \* 90 HP rated
- \* 19" high moldboard
- \* 1/4" thick moldboard
- \* 6" reversible cutting
- \* Comes with hydraulic hoses & coupler plugs
- \* Angles Hydraulically
- \* Offsets & tilts manually
- \* Optional hydraulic tilt kit available

MODEL	DESCRIPTION	WEIGHT	LIST PRICE
GB496H	8'96" HD Scraper Blade	904 lbs.	\$2249

**OPTIONS:**

MODEL	DESCRIPTION	WEIGHT	LIST PRICE
GB009HC	Hydraulic Tilt Kit	28 lbs.	\$579
	Comes with Hydraulic cylinder, hoses & coupler plug		

# SNOW BLADES SKID STEER & FRONT TRACTOR LOADERS 5' & 6' Working Widths



- \* Recommended HP 25 - 45
- \* Maximum operating weight 4,500 lbs.
- \* 2 trip springs for controlled break over in snow
- \* Blade locks for light grading of loose dirt or gravel
- \* 3/8" x 6" reversible hardened steel cutting edge
- \* 6" x 1/2" thick rotating height adjustable skid shoes
- \* 21" high moldboard
- \* Manual angle adjustment is standard
- \* Optional hydraulic angle adjustment kit available

MODEL	DESCRIPTION	WEIGHT	PRICE
SBS2160	5 ft. snow blade for compact tractors with loaders that utilize the "Universal" skid steer quick attach system	325 lbs.	\$2449
SBFL2160	5 ft. snow blade for compact tractors with loaders requiring optional interfacing quick attach brackets. Order extra	335 lbs.	\$2389
SBS2172	6 ft. snow blade for compact tractors with loaders that utilize the "Universal" skid steer quick attach system	353 lbs.	\$2539
SBFL2172	6ft. Snow blade for compact tractors with loaders requiring optional interfacing quick attach brackets. Order extra	360 lbs.	\$2429

#### **OPTIONS:**

MODEL	DESCRIPTION	WEIGHT	LIST PRICE
360170	Optional hydraulic angle adjustment kit includes cylinders, fittings and hoses between cylinders. Does NOT INCLUDE hydraulic hoses or quick couplers to tractor remotes	40 lbs.	\$509
360065	Optional crossover relief valve protects blade from damage	7 lbs.	\$339
360220	Optional top deflector for 5ft blade		\$155
360223	Optional top deflector for 6ft blade		\$259
360235	Optional sight indicators		\$55

Weights indicated are base machine weight, not shipping weight

# SNOW BLADES SKID STEER & FRONT TRACTOR LOADERS 7.5' & 9' Working Widths



- \* Recommended HP 30 - 80
- \* 2 trip springs for controlled break over in snow
- \* Blade locks for light grading of loose dirt or gravel
- \* 3/8" x 6" reversible hardened steel cutting edge
- \* 6" x 1/2" thick rotating height adjustable skid shoes
- \* 27" high moldboard
- \* 5 degree lateral oscillation
- \* Manual angle adjustment is standard 7.5 ft model
- \* Optional hydraulic angle kit available for 7.5 ft model
- \* Hydraulic angle adjustment standard on 9 ft model

MODEL	DESCRIPTION	WEIGHT	PRICE
SBS2790A	7.5 ft. snow blade for tractors with loaders or skid steers that utilize the "Universal" skid steer quick attach system	646 lbs.	\$3349
SBFL2790A	7.5 ft. snow blade for tractors with loaders requiring optional interfacing quick attach brackets. Order extra	660 lbs.	\$3279
SBS27108A	9 ft. snow blade for tractors with loaders or skid steers that utilize the "Universal" skid steer quick attach system Includes 360065 crossover relief valve	735 lbs.	\$4679
SBFL27108A	9 ft. snow blade for tractors with loaders requiring optional interfacing quick attach brackets. Order extra Includes 360065 crossover relief valve	748 lbs.	\$4599

## OPTIONS:

MODEL	DESCRIPTION	WEIGHT	LIST PRICE
360168	Optional hydraulic angle adjustment kit includes cylinders, fittings and hoses between cylinders. Does NOT INCLUDE hydraulic hoses or quick couplers to tractor remotes	40 lbs.	\$439
360065	Optional crossover relief valve protects blade from damage	7 lbs.	\$339
360227	Optional top deflector for 7.5 ft blade		\$205
360230	Optional top deflector for 9 ft blade		\$269
360235	Optional sight indicators		\$55



# SNOW BLADES CLAMP-ON TO BUCKET



- \* Available in 5' & 6' widths
- \* 21" high moldboard
- \* Uses chain & turnbuckle to fasten to material bucket
- \* For tractor loaders & skid steers up to 35 HP

MODEL	DESCRIPTION	WEIGHT	PRICE
SBC2160	5' / 60" clamp-on snow blade	305 lbs.	\$2169
SBC2172	6' / 72" clamp-on snow blade	335 lbs.	\$2239

## **OPTIONS:**

MODEL	DESCRIPTION	LIST PRICE
360220	Optional top deflector for 5ft blade	\$155
360223	Optional top deflector for 6ft blade	\$259

# BOX SCRAPERS

## Standard Duty 3 Pt.

### 3100 Series



These affordable 3 Pt. box scraper blades built by TITAN Implement are ideal attachment for tractors up to 55 HP. They have a reversible and a replaceable 6" cutting edge. They come with scarifier shanks to help breakup hard packed ground. Manufactured in U.S.A.

- \* Cat. I – 3 Pt. Hitch
- \* Rated for tractors 15 to 55 HP
- \* Available in 4', 5', 6', 7', & 8' working widths
- \* Moldboard height 17" high
- \* Overall depth 22"
- \* 6" reversible & replaceable cutting edge
- \* Quick hitch compatible

MODEL	WIDTH	# SCARIFIERS	WEIGHT	LIST PRICE
3104	4' / 48" working width	3	290 lbs.	\$689
3105	5' / 60" working width	4	323 lbs.	\$789
3106	6' / 72" working width	5	357 lbs.	\$889
3107	7' / 84" working width	6	390 lbs.	\$999
3108	8' / 96" working width	7	421 lbs.	\$1070

# BOX SCRAPERS

## Heavy Duty



These heavy duty series of box scrapers are available in widths up to 8'. They are ideal for the professional landscaper or farmer. They come complete with hinged rear moldboard for smoother grading and front and rear cutting edge with scarifier shanks. Category 1 pins on 5' and 6' models. Category 2 pins on 7' and 8' models. Horsepower rating of 30 to 90 HP.

- \* Solid welded frame with welded A-Frame
- \* Radius formed moldboard for efficient loading and unloading
- \* High clearance scarifier bar for less trash build up
- \* Hinged free floating rear cutting edge for smoother grading
- \* HP Requirements: 30-90
- \* Moldboard height 18"
- \* Depth 21-1/2"
- \* Two heat treated 1080 grade 1/2" x 6" reversible cutting edges
- \* 3/8" thick end plates

MODEL	WIDTH	# SHANKS	LOAD CAPACITY	WEIGHT	LIST PRICE
TB260	5'	5	17.50 Cu. Ft.	586 lbs.	\$1395
TB272	6'	6	21.00 Cu. Ft.	661 lbs.	\$1570
TB284	7'	8	24.50 Cu. Ft.	841 lbs.	\$1689
TB296	8'	9	28.00 Cu. Ft.	904 lbs.	\$1929

# BOX SCRAPERS

## HYDRAULIC RETRACTABLE

### TB30 Series



Tufline's TB30 series hydraulic retractable scarifier box blades are designed to break through tough ground and easily handle a variety of earth-moving jobs. The hydraulic scarifier bar makes adjustments from the operator's seat convenient. The scarifier bar is constructed of heavy duty welded mast and tubular reinforced steel for durability. The large capacity steel box has a dual sided hinged tailgate to allow for scraping, leveling, and back filling. The cutting edges are 1/2" x 6" steel and are reversible for extended life. The blade is 20" high and the end plates are 3/8" thick. 5' & 6' models are Cat. I – 3 Pt. hitch, 7' & 8' models are Cat. I/II – 3 Pt. hitch. Includes hydraulic cylinder & hose kit.

- \* **Solid welded frame with welded A-Frame**
- \* **Radius formed moldboard for efficient loading and unloading**
- \* **High clearance hydraulically operated scarifier bar**
- \* **Hinged free floating rear cutting edge for smoother grading**
- \* **Two heat treated 1080 grade 1/2" x 6" reversible cutting edges**
- \* **3/8" thick end plates**
- \* **Hi-strength adjustable scarifier shanks**
- \* **Designed for up to 80 HP**
- \* **Moldboard height 20"**
- \* **Box depth 22"**

MODEL	WIDTH	# SHANKS	LOAD CAPACITY	WEIGHT	LIST PRICE
TB3060H	5'	6	21.8 Cu. Ft.	725 lbs.	\$3229
TB3072H	6'	6	26.2 Cu. Ft.	815 lbs.	\$3529
TB3084H	7'	8	30.5 Cu. Ft.	1052 lbs.	\$3859
TB3096H	8'	8	34.9 Cu. Ft.	1146 lbs.	\$4059

# BOX SCRAPERS

## Hi-Capacity without Scarifiers



These box scrapers without scarifiers by **MONROE TUFLINE** are ideal for several applications. Use them for poultry houses, dairy barns and snow removal.

- \* Solid welded frame with welded A-Frame
- \* Radius formed moldboard for efficient loading and unloading
- \* One heat treated 1080 grade 1/2" x 6" reversible cutting edges
- \* Designed for up to 75 HP
- \* Moldboard height 25"
- \* Box depth 36"
- \* Cat. 1 and 2, 3 Pt. hitch

MODEL	WIDTH	CAPACITY	WEIGHT	LIST PRICE
PHB84	7'	44 Cu. Ft.	684 lbs.	\$1499
PHB96	8'	50 Cu. Ft.	748 lbs.	\$1579

### OPTIONS:

MODEL	DESCRIPTION	WEIGHT	LIST PRICE
SSPHB	Adjustable skid shoes (pair)	20 lbs.	\$129

Weights indicated are base machine weight, not shipping weight

# BOX SCRAPER

## CBS Series



The Monroe Tufline CBS Series corral box scraper takes the proven Tufline box scraper series to another level. These heavy duty implements are ideal for cleaning barn lots, poultry house, snow removal and general land leveling and grading. The CBS Series box scraper is constructed of 4" square tubing, 1/4" moldboard with 1/2" x 6" reversible cutting edge, and 3/8" endplates.

- \* **Constructed of 4" Square Tubing**
- \* **1/4" Thick Moldboard**
- \* **3/8" Thick End Plates**
- \* **Heat Treated 1080 Grade 1/2 X 6" Reversible Cutting Edge**
- \* **27" High x 36" Inside Depth**
- \* **Cat. I or II 3 Pt. hitch**

MODEL	DESCRIPTION	HP REQ'D	CAPACITY	WEIGHT	PRICE
CBS84	7' box scraper	35-80 HP	44 Cu. ft	725 lbs	\$1869
CBS96	8' box scraper	45-100 HP	50 Cu. ft	815 lbs	\$2019
CBS120	10' box scraper	55-120 HP	60 Cu. ft	1010 lbs	\$2329

# BOX SCRAPER PULL TYPE



The Monroe Tufline pull type box scraper takes the proven Tufline box scraper series to another level. These heavy duty implements are ideal for cleaning barn lots, driveway grading, filling pot holes and general land leveling and grading. With tilting ability this is an excellent machine for crowning gravel roads or lanes, shaping slopes or cutting ditches.

- \* **Constructed of 4" Square Tubing**
- \* **1/4" Thick Moldboard**
- \* **3/8" Thick End Plates**
- \* **Heat Treated 1080 Grade 1/2 X 6" Reversible Cutting Edge**
- \* **Includes Hydraulic Cylinders and Hoses**
- \* **Tilting Ability**
- \* **Clevis Hitch**
- \* **9.5L x 15" Implement Tires**
- \* **Includes Implement Tongue Jack**

MODEL	DESCRIPTION	HP REQ'D	CAPACITY	WEIGHT	PRICE
DS196T	8' box scraper	35-80 HP	44 Cu. ft	1300 lbs	\$5399
DS1120T	10' box scraper	45-100 HP	50 Cu. ft	1450 lbs	\$5539
DS1144T	12' box scraper	55-120 HP	60 Cu. ft	1600 lbs	\$5729

# LAND PLANES

## LP Series



Tufline's LP Series land planes are ideal for gravel road reconditioning, driveway grading, pot hole filling, and general land levelling and grading. The LP series offers high strength reversible, double bevel cutting edges for unique dual blade grading performance. Constructed of heavy 3" square tubing, 3/16" thick plate & channel make the main frame rugged. Models 5' & 6' are Cat. I, 3 Pt. hitch. Models 7' & 8' are Cat. I - II, 3 Pt. hitch.

MODEL	WIDTH	WEIGHT	LIST PRICE
LP160	5'	482 lbs.	\$1439
LP172	6'	532 lbs.	\$1529
LP184	7'	598 lbs.	\$1619
LP196	8'	642 lbs.	\$1729

## LP3 Series Heavy Duty



The LP3 series comes with two 1/2" x 6" cutting blades, with removal, rugged scarifiers to rip up any hard compacted ground. Then finish it with a smooth grade to flatten and level the soil. Constructed of 4" x 4" x 3/8" thick square tubing, along with 60" x 20" x thick side plates with adjustable skid shoes to set grading depth. Cat. I & II 3 Pt. hitch, quick hitch adaptable.

MODEL	WIDTH	SHANKS	WEIGHT	LIST PRICE
LP384	7'84"	4	908 lbs	\$3049
LP396	8'96"	6	1110 lbs	\$3219
LP3120	10'120"	8	1254 lbs.	\$3559





# AMAZONE

The CATROS compact disc harrows from AMAZONE make work go by twice as quick ! Being easy to pull, these machines allow for high speed travelling but still leave a top class quality of work.

High work rates, low fuel consumption and low wear costs are the special strengths of the CATROS. They are ideally suited for a fast, shallow and intense mixing stubble work and operate blockage free even in high amounts of stubble. The incorporation of straw and stubble, the loosening up of grassland, seedbed preparation and the incorporation of organic manures offers additional flexibility in use. The broad range includes mounted and trailed machines in working widths from 3 meters to 7.5 meters.



**ONLY AVAILABLE THROUGH STOCKING DEALERS**



# AMAZONE

# POWERED LANDSCAPE RAKES



PTC Model for 3 Pt. Hitch



PSS Model for Skid Steer



PXS Model for "Mini" Skid Steer



Sabre Tooth Rotor



Carbide Rotor

# POWERED LANDSCAPE RAKES



WORKSAVER's new Powered Landscape Rakes, remove debris or sod to prepare a seedbed surface to create a new lawn or renovate an existing lawn. These powered landscape rakes also pulverize and set grade on new construction sites. Models available in 3', 4', 5' & 6' working widths to fit mini/compact skid steers. 6', 7' & 8' for standard skid steers. 5', 6', 7' & 8' for tractors with 3 Pt. hitch 540 RPM PTO. Rakes are available with your choice of 2" "SABRE TOOTH" rotors or 1-3/4" "CARBIDE TOOTH" rotors. Replaceable bearing housings and triple sealbearings provide durability and serviceability. Call your dealer for other models and sizes not listed.

- \* Working widths up to 8 ft. available
- \* Available with your choice of 2" "Sabre Tooth" or 1-3/4" "Carbide Tooth" rotors
- \* Quick flip (self storing) side shields allowing ease of wind rowing rocks and debris
- \* Flip up gauge wheels with pneumatic tires
- \* #80 roller chain drive, H.D. models double #80 chain drive
- \* Environmentally friendly dry chain case
- \* Replaceable bearing housing with triple sealed bearings
- \* Standard Manual Angle adjustment, optional hydraulic angle kits available
- \* Adjustable material bar
- \* 540 RPM PTO models come with slip clutch PTO, and Cat. I, 3 Pt. Hitch
- \* Hydraulic models to fit skid steers come with hydraulic hoses with connect under pressure couplers
- \* Optional Skid shoes available

MODEL	DESCRIPTION	WEIGHT	LIST PRICE
PXS410ST	4 ft. with "Sabre Tooth" rotor universal "mini" skid steer mount	526 lbs.	\$8475
PSS620ST	6 ft. with "Sabre Tooth" rotor universal skid steer mount	832 lbs.	\$9579
PSHD865ST	8 ft. with "Sabre Tooth" rotor universal skid steer mount	1145 lbs.	\$12,539
PTC525ST	5 ft. with "Sabre Tooth" rotor 3 Pt. hitch PTO	627 lbs.	\$8695
PTC725ST	7 ft. with "Sabre Tooth" rotor 3 Pt. hitch PTO	699 lbs.	\$9855

## OPTIONS:

MODEL	DESCRIPTION	LIST PRICE
360525	Pair of skid shoes mounts to side shield fits all models	\$165
360640	Hydraulic angle kit for PXS models with 2 sets of remotes	\$1265
360779	Hydraulic angle kit with solenoid for PSS/PSHD models with one set of remotes	\$1809

# LANDSCAPE RAKES

## 3 Pt.



5100 Series Models



LRHD Model

These landscape rakes manufactured by WORKSAVER and TITAN Implement make a great landscape rake for your tractor. With HP ratings of up to 60 HP and working widths 4' to 8' we can match your requirements with the rake your tractor can handle. Units come with heat treated spring steel teeth spaced 1' apart. Gauge wheels are optional.

- \* 1" x 5/16" x 27" tines
- \* 5 backfill angle positions 4', 5', 6' & 7'
- \* 5 forward angle positions 4', 5', 6' & 7'
- \* 7 backfill angle positions LRHD models
- \* 7 forward angle positions LRHD models
- \* Turns 360°
- \* Cat. I - 3 Pt. hitch

### TITAN IMPLEMENT

MODEL	WIDTH	HP REQ'D	WEIGHT	LIST PRICE
5104	4' / 48"	45	158 lbs.	\$575
5105	5' / 60"	45	180 lbs.	\$655

### WORKSAVER

MODEL	WIDTH	HP REQ'D	WEIGHT	LIST PRICE
MCR6	6' / 72"	40	187 lbs.	\$889
MCR7	7' / 84"	40	199 lbs.	\$929
LRHD7	7' / 84"	60	330 lbs.	\$1369
LRHD8	8' / 96"	60	365 lbs.	\$1459

#### OPTIONS:

MODEL	DESCRIPTION	WEIGHT	LIST PRICE
SGW10	Single gauge wheel kit	26 lbs.	\$299
DGW20	Dual gauge wheel kit	57 lbs.	\$539

# MIXER - PTO

## 3 Pt. Hitch & Skid Steer Hydraulic



580



SS590

These mixers by **WORKSAVER** are available in both 3 Pt. hitch and skid steer mount models and are ideal for all mixing applications. Both models come with a 5 Cu. Ft. capacity (1 bag mix).

### Cat. I, 3 PT. HITCH

- \* 540 RPM PTO
- \* Hydraulic top link cylinder provides positive dump control
- \* # 40 roller chain drives mixing drum
- \* Two piece steel drum with internal mixing paddles

### SKID STEER MOUNT

- \* Fits "Universal Style" skid-steer attachment system
- \* Hydraulically driven gear box
- \* Minimum hydraulic flow required 8 GPM
- \* Gear ratio 3.18 : 1
- \* Internally welded mixing paddles for proper mixing
- \* Includes flow control valve (On-Off) for easy operation
- \* Hydraulic hoses included with connect under pressure flat faced couplers

MODEL	DESCRIPTION	WEIGHT	LIST PRICE
580	3 Pt. PTO mixer	215 lbs.	\$1649
SS590	Skid steer hydraulic	395 lbs.	\$4539

# CARTS

## POLY

**Agri-Fab**  
Lawn Care Made Easy™



These carts will perform a variety of tasks safely, reliably and efficiently. The clean ergonomic design and sturdy construction make these carts perfect for hauling yard refuse, firewood, topsoil, sand and gravel or any other job you need moved or carried. Available in steel or poly bed construction.

### Model TC10P

#### List Price: \$205

- \* 600 lb. weight capacity
- \* Convertible push or tow dump cart
- \* Fold behind tongue / drawbar assembly
- \* One piece rustproof poly bed
- \* Bed Size 30.5" W x 41" L x 11" H
- \* Tire size 4.80" x 8" turf tire
- \* Weight 67 lbs.



### Model 450464

#### List Price: \$529

- \* 800 lbs./ 12 cu.ft. Capacity Tow cart
- \* One Piece Poly Structural Foam Construction
- \* Bed Size 58" L x 15" H x 41" W
- \* Tire Size 15" x 6"
- \* Foot lever Dumping Mechanism
- \* Weight 110 lbs.



### Model 450175

#### List Price: \$539

- \* 650 lbs. load capacity
- \* Durable poly construction
- \* Bed size 30"W x 45"L x 12"H
- \* 18" x 6.5" all-terrain pneumatic tires
- \* Wheels feature needle bearings and grease zerks
- \* Weight 93 lbs.



**See additional carts on following pages**

# CARTS STEEL



Model TC1018

**List Price: \$235**

- \* 750 lbs. load capacity
- \* Bed size 18 ga. 31"W x 42"L x 13"H
- \* Tire size 16" x 4.8" x 8" pneumatic turf tires
- \* Solid 3/4" dia. axle
- \* Removeable tailgate
- \* Easy single lever dump release
- \* Weight 99 lbs.



Model TC17

**List Price: \$405**

- \* 1500 lbs. load capacity
- \* Bed size 16 ga. 37"W x 59"L x 16"H
- \* Tire size 16" x 6.5" pneumatic turf tires
- \* Removable tailgate
- \* Easy single lever dump release
- \* Weight 171 lbs.



Model TC174

**List Price: \$605**

- \* 2000 lbs. load capacity
- \* 4 wheel, front steerable axle
- \* Bed size 16 ga. 37"W x 59"L x 16"H
- \* Bed design: one piece
- \* Tire size 16" x 6.5" - 8" pneumatic turf tires
- \* Removable tailgate
- \* Solid 3/4" steel axle
- \* Weight 224 lbs.



**See additional carts on following pages**

Weights indicated are base machine weight, not shipping weight

# ATV DUMP CARTS

## STEEL

**Agri-Fab®**  
Lawn Care Made Easy™



450240ATV



450350

**AGRI-FAB'S** heavy duty ATV dump carts are tough enough to handle your large loads at speeds up to 20 MPH. ATV carts come with needle bearing wheels, with grease zerks, on 1" diameter high carbon steel axles. Removable tailgate.

MODEL	DESCRIPTION	WEIGHT	LIST PRICE
450240ATV	Single axle with 18 x 6.50-8 all terrain pneumatic tires 1200 lb. capacity Bed size 18 ga., 46"L x 34"W x 14"H	147 lbs.	\$639
450350	Tandem Axle 1000 lb. Cap. Bed Size, 16 ga. 32.5" W x 61" L x 12" H includes steel tube railing kit comes with 18 x 9.50 all-terrain pneumatic tires	230 lbs.	\$1045



# TINE DE-THATCHERS

## Pull Type



De-thatching is very important in environmentally conscious lawn care. These de-thatchers by **AGRI-FAB** do a gentle job of bringing matted layers of thatch and large clippings to the surface for a healthy lawn.

- \* Twenty 3/16" heated tines on 40"
- \* Twenty four tines on 48"
- \* 40" and 48" working width available
- \* 7" x 1.5" semi-pneumatic tires

MODEL	WIDTH	WEIGHT	LIST PRICE
4502941	40"	33 lbs.	\$119
4502951	48"	37 lbs.	\$169

Weights indicated are base machine weight, not shipping weight

# LAWN SWEEPERS



- \* 42" wide lawn sweep
- \* 12.9 cu. ft. capacity
- \* 10" diameter brush
- \* 10-1/2" rubber tire

- \* 48" wide lawn sweeper
- \* 14.9 cu. ft. capacity
- \* 10" diameter brush
- \* 10-1/2" rubber tire

MODEL	DESCRIPTION	WEIGHT	LIST PRICE
TL31108	42" Pull type lawn sweeper	77 lbs.	\$315
TL31109	48" Pull type lawn sweeper	86 lbs.	\$359

# LAWN SWEEPER SMARTSWEEP



The NEW SmartSWEEP from Agri-Fab is designed to make sweeping up yard debris easier than ever. This unit doesn't skip, solving the #1 consumer frustration with current lawn sweepers. 25 cu. ft. hopper capacity. Exclusive patent pending offset hitch design allows users to simultaneously cut and sweep lawn clippings or leaves. Exclusive, patent pending ergonomic dumping mechanism, no more rope to pull. One button brush height adjustment, adjusts just the brush, not the whole unit.

- \* 44" sweeping width
- \* 25 cu.ft. hopper capacity
- \* #4 - 12" diameter brushes
- \* Offsetable hitch
- \* Ergonomic dumping mechanism
- \* One button brush height adjustment
- \* Design allows sweeper to collapse for compact storage

MODEL	DESCRIPTION	WEIGHT	PRICE
450492	44" SmartSWEEP	94 lbs.	\$495

### OPTIONS:

MODEL	DESCRIPTION	WEIGHT	LIST PRICE
4503433	Front mount tine de-thatcher fits above "TOW TYPE" sweepers	23 lbs.	\$105

# LAWN VACS



55249



55188

For any size yard, Agri-Fab's **Mow-N-Vac** or **Chip-N-Vac** offer proven performance. 80 MPH worth of suction provides enough power to collect large quantities of grass, leaves, twigs, pine needles, etc. that can be dumped effectively with any of Agri-Fab's vac systems. All units include a safety engine shut-off which prevents accidental engine start-ups, a universal fit mower deck adapter. Units fit only right hand discharge mid-mount mowers. Optional 65640 hose kit is required for front mount zero turn mowers.

MODEL	DESCRIPTION	WEIGHT	LIST PRICE
55188	Hard Top <b>Mow-N-Vac</b> with 205cc B&S Intek engine. Large 26 bushel/32 cu.ft. capacity Includes cart with durable vented hard top design.	340 lbs.	\$1999
55249	Hard Top <b>Chip-N-Vac</b> with 205cc B & S engine. Large 26 bushel/32 cu.ft. capacity, chips up to 2" Dia. brush. Includes cart with durable vented hard top design	384 lbs.	\$2299

**OPTIONS:**

MODEL	DESCRIPTION	WEIGHT	LIST PRICE
450253	5" x 12' long, remote hose kit for vacuuming flower beds and from under trees	19 lbs.	\$225
65640	Hose extension kit with adapter for zero turn. Front mount mower deck		\$105

# SMARTLINK ATTACHMENTS

**Agri-Fab**  
Lawn Care Made Easy



450473  
Master Platform



450459



450458



450457

450474  
Core/Plugger Aerator

The NEW SmartLINK system from Agri-Fab allows users to switch from one lawn implement to another in seconds without tools. Purchase the "master platform" and then any of the four different attachments, 40" TURF SHARK™ Curved Blade Aerator, 40" Core/Plugger Aerator, 40" Tine dethatcher or 40" x 18" Poly Lawn Roller as required or purchase all five pieces. Dethatch, roll, spike or aerator your lawn with the pull type master platform that can be easily hooked to any lawn tractor. SmartLINK lawn care system provides unprecedented versatility and can be easily stored.

- \* Master platform provides durable heavy gauge steel deck and drawbar
- \* Universal hitch fits any lawn tractor
- \* Rustproof aerator/core knives allows air, water and nutrients to reach into the soil
- \* Patented Turf Shark™ spike aerator designed for thorough soil penetration without messy soil plugs
- \* Tine dethatcher effectively loosens and lifts thatch for healthier lawn growth
- \* 40" x 18" poly lawn roller weighs up to 400 lbs, levels sod, packs fresh seeding, levels frost heaving ground and more

MODEL	DESCRIPTION	WEIGHT	LIST PRICE
450453Q	Master Platform with ALL 4 Attachments	158 lbs.	\$695
450473	Master Platform	60 lbs.	\$195
450474	40" Core/Plugger Aerator	29 lbs.	\$122
450458	40" Turf Shark™ Curved Blade Spike Aerator	23 lbs.	\$109
450457	40" Tine Dethatcher	19 lbs.	\$99
450459	40" Poly Lawn Roller Capacity 400 lbs	27 lbs.	\$185

# CORE /PLUG AERATOR Pull Type

**Agri-Fab®**  
Lawn Care Made Easy™

**YARD  
COMMANDER™**



450299



TL31202

Core aerating is increasingly important in aesthetically and environmentally conscious lawn care. These core aerators by **AGRI-FAB** and **YARD COMMANDER** are perfect for highly compacted clay soil conditions allowing seed, fertilizer, air and water to reach deep into the lawns roots.

### 450299

- \* 48" working width
- \* 3" aeration depth
- \* 32 heat treated points
- \* Tray capacity 140 lbs.
- \* 10" x 4" pneumatic tires
- \* Single hand lift lever

### TL31202

- \* 60" working width
- \* 3" aeration depth
- \* 40 heat treated points
- \* Tray capacity 200 lbs.
- \* 10" x 4" pneumatic tires
- \* Single hand lift lever

MODEL	DESCRIPTION	WEIGHT	LIST PRICE
450299	Agri-Fab 48" 32 plug core aerator	91 lbs.	\$299
TL31202	Yard Commander 60" 40 plug core aerator	136 lbs.	\$329

# SPIKE AERATOR



Aeration allows water, sunlight, fertilizer and nutrients to reach the grass roots for a healthy lawn. The curved spike aerators spike wheel provides the perfect amount of penetration and soil plug removal without the mess associated with plug aerators.

- \* Simple to use single lever wheel engaging for easy transport
- \* 40" Weight tray
- \* 12-9" rust-resistant, galvanized curved discs

MODEL	DESCRIPTION	WEIGHT	LIST PRICE
450369	40" "Turf Shark" Curved Spike Aerator	54 lbs.	\$219

# LAWN ROLLERS



450216 Shown (Steel)



LRP2448B Shown (Poly)

Uneven ground from frost heaving, newly sewn lawns or sod that just needs to be packed down, are ideal jobs for these **AGRI-FAB** lawn rollers. These steel or poly tow rollers can be used for light or heavy duty performance.

MODEL	ROLLER DRUM	WEIGHT W/WATER	SHIPPING WEIGHT	LIST PRICE
LRP2448B	<b>POLY</b> 24" dia. x 48" wide	825 lbs.	82 lbs.	\$325
450179	<b>STEEL</b> 24" dia. x 36" wide	640 lbs.	110 lbs.	\$289
450216	<b>STEEL</b> 24" dia. x 48" wide	910 lbs.	170 lbs.	\$375



# DRUM SPIKER



The YARD COMMANDER Tow Behind Drum Spiker is a versatile implement for Aerating and lawn compaction of frost heaves in the spring of the year. Helps nutrients get into soil and down to the roots. This unit can be attached to any lawn and garden tractor or ATV.

- \* Pull/Tow Type
- \* 60" x 14" Diameter Drum
- \* 126 Steel Spikes Penetrates the Ground up to 2-1/2"
- \* Drum holds 31 Gallons of Water
- \* Adds 460 lbs. of Weight

MODEL	DESCRIPTION	WEIGHT	LIST PRICE
TL31112	60" Drum spike aerator	186 lbs.	\$549

# SPREADERS

## Broadcast - Push Type



450388



4502142  
w/65353

Broadcast spreaders spread everything from fertilizer, seed, ice melters and more. Solid construction and reliable design ensures even and continuous flow and spread of materials, eliminating streaks. Hoppers constructed of weather resistant polyethylene.

MODEL	DESCRIPTION	WEIGHT	LIST PRICE
450388	85 Lb. Capacity 10" x 4" pneumatic tires. Up to 10' Spread width	20 lbs.	\$99
4502142	100 Lb. Capacity 10" x 4" pneumatic tires. 8' to 10' spread width	33 lbs.	\$180

### OPTION:

MODEL	DESCRIPTION	LIST PRICE
65353	Deflector skirt for ice melter	\$31
40883	85 lb - 100 lb hopper cover	\$19

# SPREADERS

## Broadcast - Tow Type



4502152



450315

Broadcast spreaders spread everything from fertilizer, seed, ice melters and more. Solid construction and reliable design ensures even and continuous flow and spread of materials, eliminating streaks. Hoppers constructed of weather resistant polyethylene. On/Off Control is accessible from tractor seat

MODEL	DESCRIPTION	WEIGHT	LIST PRICE
450315	85 lbs. Cap 10" x 4" pneumatic tires Up to 10' Spread Width	17 lbs.	\$99
4502152	100 Lb. Cap. 10" x 4" pneumatic tires 8' to 10' spread width	33 lbs.	\$180

### OPTION:

MODEL	DESCRIPTION	LIST PRICE
65353	Deflector kit for ice melter	\$31
40883	85 lb - 100 lb hopper cover	\$19

# SALT SPREADER

## Broadcast Push-Type



This spreader was specifically designed to spread ice salt, ice melter and more. Solid construction and reliable design ensures even and continuous flow and spread of materials, eliminating streaking. Hopper constructed of weather resistant polyethylene. Stainless steel frame, axle and hardware.

- \* 125 lb. Capacity
- \* Push Type
- \* Spread Width 10' – 12' depending on material being spread
- \* 6.00 – 6 pneumatic turf tire (14" diameter)
- \* Poly Hopper
- \* Stainless Steel Frame & Spreader Plate, Axle & Hardware
- \* H.D. Stainless Steel Gear
- \* Includes grate/screen and weatherproof cover
- \* Deflector Kit to reduce spread width
- \* Rate setting control on handle for precise adjustments

MODEL	DESCRIPTION	WEIGHT	LIST PRICE
TL31520	125 lb. capacity, push type 6.00 x 6 pneumatic tires c/w screen/grate weather cover & deflector kit	41 lbs.	\$489

# SPREADER

## Broadcast

## Pull-Type



Broadcast spreaders spread everything from fertilizer, seed, ice melter and more. Solid construction and reliable design ensures even and continuous flow and spread of materials, eliminating streaking. Hopper constructed of weather resistant polyethylene. On/off control is accessible from tractor seat.

- \* 175 lb. Capacity
- \* Spread Width 10' – 12' depending on material being spread
- \* 6.00 x 6 pneumatic tire
- \* Poly Hopper
- \* Rust Proof Spreader Plate
- \* H.D. Aluminum Gear
- \* Includes grate/screen and weatherproof cover

MODEL	DESCRIPTION	WEIGHT	LIST PRICE
TL31510	175 lb. capacity, tow type 6.00 x 6 pneumatic tires c/w screen and weather cover	53 lbs.	\$339

# SPREADERS

## SmartSPREADER

**Agri-Fab**  
Lawn Care Made Easy



- \* 130 lb. capacity
- \* Unique, user friendly spreader-setting knob for precise fertilizer application
- \* Spring loaded ON/OFF lever

MODEL	DESCRIPTION	WEIGHT	LIST PRICE
450462	SmartSPREADER Push	37 lbs.	\$259
450463	SmartSPREADER Tow	37 lbs.	\$259

### OPTION:

MODEL	DESCRIPTION	LIST PRICE
41316	Hopper cover	\$22
67660	PRO KIT for 450462 Includes adjustable shield, cushion handles & hopper cover	\$95
67663	SPREADER GRATE KIT for 450462	\$65

# SPREADERS

## Broadcast 12 Volt



DMSTR12V22



ATVDMS12V

The Fimco ATV spreader has a 2.2 cubic foot poly hopper which has a capacity of up to 145 lbs. depending on type of material. Stainless steel radial 6 blade fan/spinner can spread material up to 45 feet (depending on type of material). Can be used with fertilizer, seed, powders, granular, insecticides, fungicides and herbicides & ice melter.

- \* 2.2 cu. ft. rust proof poly hopper
- \* Up to 145 lb. capacity
- \* 5 ft. to 45 ft. variable spread width
- \* Stainless steel radial 6 blade fan / spinner
- \* 12 volt motor with variable speed control with On-Off switch
- \* Universal ATV mounting
- \* Pull type tire size 15/600 x 6

MODEL	DESCRIPTION	WEIGHT	LIST PRICE
ATVDMS12V	ATV mounted spreader	56 lbs.	\$489
DMSTR12V22	ATV pull type spreader	59 lbs.	\$519

### OPTIONS:

MODEL	DESCRIPTION	LIST PRICE
5058193	Clear hopper cover	\$10
5301901	2" receiver hitch	\$120

# DROP FERTILIZER SPREADER

**Agri-Fab**  
Lawn Care Made Easy™



450288

The Agri-Fab drop spreader is the proper tool for overseeding, weed control, fertilizing and more. You can count on the Agri-Fab spreader to help. Designed for easy operation and even coverage, our spreaders will give you great results time after time.

- \* 175 lbs. capacity
- \* 42" spread width
- \* 3/4" axle
- \* Covers approx. 40,000 sq. ft.
- \* Premium galvanized steel agitator.
- \* Spreader settings for a multiple of materials.
- \* Ground Drive

MODEL	DESCRIPTION	WEIGHT	LIST PRICE
450288	Drop fertilizer spreader 14" x 4" pneumatic tires	45 lbs.	\$305



# SPIKER SEEDER DROP SPREADER



The YARD COMMANDER Tow Behind Spiker/Seeder/Drop Spreader is a versatile implement for spreading seed, fertilizer, or for over seeding lawns. This unit can be attached to any lawn and garden tractor or ATV.

- \* **Tow Type**
- \* **175 lb.(80 L) capacity**
- \* **Approximate coverage 40,000 sq. ft.**
- \* **Spread Width 40"**
- \* **Poly Hopper is Rust Proof**
- \* **12 Spike Wheels, 7" Diameter**
- \* **3.50 - 4 x 10" Pneumatic Tires**

MODEL	DESCRIPTION	WEIGHT	LIST PRICE
TL31519	Spiker/Spreader/Over Seeder	70 lbs.	\$369

# SPREADER

## 3 Pt. Hitch, 12 volt



The FIMCO 3 Pt. hitch spreader features a tough, corrosion - resistant 5.0 cu.ft. / 200 lb. capacity poly hopper with a stainless steel radial six blade spreading fan. Adjustable slide gate allows you to control the amount of material you're spreading, and can be opened or closed with a simple turn of the on/off handle. The FIMCO spreader uses a variable-speed 12 volt motor (with on/off switch) that lets you change the spread width from 5 ft. to 45 ft. (depending on material being spread).

- \* Poly Hopper
- \* 5.0 Cu.ft. / 200 lb. capacity
- \* CAT I, 3 Pt hitch
- \* Stainless steel radial six blade spreader fan
- \* 12 volt motor
- \* Variable speed controller
- \* Wiring harness to power supply

MODEL	DESCRIPTION	WEIGHT	LIST PRICE
DMS3PT12V50	Spreader 200 lb. capacity 12 volt	125 lbs.	\$669

# ATV SEEDER & SPREADER



The WORKSAVER ATV Seeder & Spreader helps get a head start early in the season for seeding pastures or cover crops and fertilizers. The 12 volt electric ATV seeder has a 1 bushel poly hopper to promote longer life. The adjustable flow control mounted on the ATVK400 is easy to adjust and provides better control over material flow. Universal mounting fits most makes and models of ATV's.

- \* 12 volt electric motor with variable speed control
- \* 1 bushel poly hopper is translucent for easy monitoring of hopper material level
- \* Snap-on lid to prevent seed from blowing out and keep moisture out
- \* Proven 2-opening seed gate that closes tightly and reopened to the same setting
- \* A mud and water shield to protect the spreader fan
- \* Complete wiring harness with simple clips to fasten to battery terminals
- \* Lightweight, high strength design allows operator to easily mount or dismount unit from ATV
- \* Flow control lever and seeding chart is easily accessible to the operator
- \* Universal mounting fits most makes and models of ATV's
- \* Mounts to rear rack of ATV

MODEL	DESCRIPTION	WEIGHT	LIST PRICE
ATVK400	ATV Seeder & Spreader	42 lbs.	\$589

# SPREADERS

## Baby-Hop

### Ground Driven



Easy connecting pull type hitch, ground controlled distribution, and rugged construction makes the **BEFCO** Baby-Hop spreader the perfect companion for your ATV, riding mower or small garden tractor. Ideally suited for even distribution of fertilizer, seed, salt and dry sand. Baby-Hop spreaders come complete with:

- \* One piece seamless painted steel hopper
- \* Even spread left-center-right pattern
- \* High flotation air tires
- \* 103-130: 13x5.00-6
- \* 106-130: 16x6.50-8
- \* Easy connecting pull type hitch
- \* Sturdy tubular frame
- \* Hopper levelling adjustment
- \* Sealed heavy duty gearbox

MODEL	HOPPER CAPACITY CU.FT/LBS	SWATH SPREAD	WEIGHT	LIST PRICE
103-130	3.5 / 226	20'	62 lbs.	\$825
106-130	5.6 / 362	20'	84 lbs.	\$1099

**NOTE:** Poundage capacity calculated at 13-13-13 fertilizer weight of 64 Lbs./Cu. Ft.

#### OPTIONS:

MODEL	DESCRIPTION	LIST PRICE
AA1-120	Deflector shield-reduces spreading width to approximately 4'	\$112

# SPREADERS

## Spin Type

### Steel



These quality spreaders are designed for tractors from 16 to 30 HP, 540 PTO RPM, Category 1, 3 Pt. hitch. Ideal for distribution of fertilizer, seed, salt, dry sand and much more. Spreaders come complete with:

- \* **HP Requirements: 16-30, 540 RPM**
- \* **One piece seamless painted steel hopper**
- \* **Three different spread patterns**
- \* **Heavy duty shielded PTO shaft (1-3/8" ASAE Cat. 1)**
- \* **Sturdy tubular frame**
- \* **Selective double gate opening**
- \* **Sealed heavy duty gearbox**
- \* **Fixed agitator**
- \* **Cat. 1, 3 Pt Hitch on all models**

HOPPER CAPACITY			
MODEL	CU.FT/LBS	WEIGHT	LIST PRICE
203-120	3.5 / 226	81 lbs.	\$809
206-121	4.8 / 311	102 lbs.	\$839
209-121	10.6 / 678	125 lbs.	\$885
212-121	17.6 / 1130	136 lbs.	\$935

**NOTE:** Poundage capacity calculated at 13-13-13 fertilizer weight of 64 Lbs./Cu. Ft.

#### **OPTIONS:**

MODEL	DESCRIPTION	LIST PRICE
009-9524	Deflector shield fits model 203 & 206	\$115
009-9979	Tumbling style agitator 203 model only	\$95
009-9638	Deflector shield fits model 209 & 212	\$219
009-9978	Tumbling style agitator for 206, 209 and 212	\$95
AA4-120	Siderow discharge for model 209 & 212 only	\$475

Weights indicated are base machine weight, not shipping weight

# SPREADERS

## SPIN TYPE - POLY HOPPER



BRI poly hopper spreaders are available in two models, Cat. I 3 Pt hitch, 540 RPM PTO. Bottom opening gates ensure a constant and accurate flow of material to spinner. Variable positioning gate openings and fin adjustments allow material to drop on different positions of the spinning disc, therefore giving a left-right-center spread pattern. Maintain a constant homogenous blend of any and all combinations of fertilizers, seeds, fungicides, herbicides, etc. with the BLENDER option. The blender option offers a unique fountain blending system which keeps a consistent mix of any and all product being spread. Only available on model SSP400

- \* Durable no-rust Poly Hopper
- \* Cat. I 3 Pt. Hitch
- \* 540 RPM PTO
- \* Simple adjustable left-right-center spread pattern
- \* Galvanized spin disc with multi-positioning adjustable fins
- \* Maximum spread pattern 49 feet depending on material being spread

MODEL	DESCRIPTION	WEIGHT	LIST PRICE
SSP250	575 LB. / 196 Litres	123 lbs.	\$699
SSP400	860 LB. / 293 Litres	130 lbs.	\$719

# SPREADERS

## Turbo Hop 3 Pt.



301-300 Shown



303-600 Shown

Turbo Hop spreaders are designed for tractors from 20 to 60 HP, 540 PTO RPM, with a maximum spread swath of 40'-46'. Ideal for distribution of fertilizer, seed, salt, dry sand where accuracy and precision in application is needed. Turbo Hop spreaders come complete with:

- \* HP Requirements: 20-60, 540 RPM
- \* Polyethylene hopper
- \* Spreader spouts made of nylon and reinforced fiberglass
- \* Stainless steel opening control disc
- \* Cast steel anti-wear agitator
- \* Heavy duty shielded PTO shaft (1-3/8" ASAE Cat. 1)
- \* Sturdy tubular frame
- \* Micrometric flow control adjustment
- \* Heavy duty cast steel gearbox in oil bath
- \* 301-300-400 cone type hopper Cat. I / II 3Pt. hitch
- \* 303-600-999 retantgular type hopper Cat. I / II 3Pt. hitch

MODEL	HOPPER CAPACITY		SPREAD		LIST PRICE
	CU.FT/LBS		WIDTH	WEIGHT	
301-300	9.00 / 576		17'- 47'	256 lbs.	\$3180
301-400	12.80 / 820		17' - 47'	267 lbs.	\$3469
303-600	20.6 / 1318		17'- 47'	419 lbs.	\$4255
303-999	36.1 / 2310		17'- 47'	455 lbs.	\$5100

**NOTE:** Poundage capacity calculated @ 13-13-13 fertilizer weight of 64 lbs. per cubic foot

### OPTIONS:

MODEL	DESCRIPTION	LIST PRICE
001-4984	Locking Nut for Spout	\$55
009-5370	Left ONLY & Right ONLY Directional Attach	\$89
009-9451	Rubber Insert for Damp Material for 301	\$135
009-9913	Filter Grate for 301 models	\$545
009-5410	Filter Grate for 303 models	\$515
009-9452	Short Spout for Sand and Salt	\$365
009-9453	Agitator Extension for 301 models	\$219
009-9454	Agitator Extension for 303 models	\$219
009-9456	Hydraulic Controls for 301 models	\$945
009-9455	Hydraulic Controls for 303 models	\$945

Weights indicated are base machine weight, not shipping weight

# ZA-M FERTILIZER SPREADERS

ONLY AVAILABLE THROUGH STOCKING DEALERS



## SBS – Soft Ballistic System

Mineral fertilizer needs to be gently handled to ensure a precise distribution and an exact placement to the plant over the entire working width. Fertilizer, which has been damaged while going through the spreader, will not be precisely distributed. The AMAZONE Soft Ballistic System is integrated into all ZA-M mounted spreaders where the agitator, metering components and spreading discs are all optimally matched to protect the fertilizer and ensure even distribution over the entire working width.

## Stainless Steel Spreading System

The entire spreading system of the ZA-M spreaders is made from stainless steel: Hopper tips and agitator spirals. Entire base plates with setting rate slides and hydraulic shutters. Spreading discs with the spreading vanes Fully enclosed deflector plates

## Oil Bath Gearboxes

The oil bath gearboxes have proven to be the indestructible heart of the AMAZONE twin disc centrifugal spreader. Repetitive test procedures are conducted. They are maintenance free and provide integrated overload safety to prevent gearbox damage. Rate Adjustment: Simple – Reliable – Precise The spreading rate and the working width are preselected from the extremely-comprehensive setting chart. Clear easy to read scales help you to set the spreading rate exactly using the shutter slide.

## The Double Shutter Control System

The rate shutters and on-off shutters can be operated independently of each other. The double acting hydraulic slides ensure an instantaneous opening and closing of the shutters at ends of the field.

## OM Omnia-Set Spreading Discs

The OM Omnia-Set spreading discs are equipped with pivoting spreading vanes that generate a spread pattern that is extremely precise and safe. With the aid of an easily readable scale that is in the users field of view, the spreading vanes can be adjusted easily and exactly without tools. AMAZONE provides comprehensive setting charts for all kinds of fertilizer and seed. The OM Omnia-Set spreading discs are made from stainless steel and are easily installed.



# ZA-M FERTILIZER SPREADERS



Today's farmer and agricultural custom operators need fertilizer spreaders where, safety, accuracy and dependability come first. AMAZONE is safe in every respect: on the road, in the field, during adjustment and while spreading. It is not just about saving money, but also protecting the environment and ensuring safety on the road as well as accuracy in the field with accurate spreading of your fertilizer.

- \* **Important Parts in Stainless Steel**
- \* **Square Shallow Twin Tip Hopper**
- \* **Indestructible Oil Bath Gearboxes**
- \* **c/w Stainless Steel OM 24-36 Spreading Discs**
- \* **Stainless Steel Guard Tube to Protect Spreading Discs**
- \* **Spiral Agitators Ensure a Very Even Fertilizer Flow**
- \* **Hydraulic Single Shutter Slide Control for the Right or Left Hand Side**
- \* **Standard with Traffic Lights and Warning Plates**
- \* **Filling Sieve against Foreign Particles**
- \* **540 RPM PTO Shaft**
- \* **CAT II 3 Pt. Hitch**
- \* **Maximum Payload up to 6835 lbs. (3100kg)**
- \* **Calibration Device for the Simple Check of the Pre-Adjusted Spread Rate**
- \* **Comprehensive Setting Charts for all Types of Fertilizer Calculation Disc Rule to Determine the Required Shutter Slide Position**
- \* **Optional Spreading Disc, Hopper Extensions, Hopper Covers, Border Spreading Devices available**

MODEL	DESCRIPTION	WEIGHT (LBS.)	LIST PRICE
ZAM1501	1500 L / 395 gal capacity c/w spreading width of 24 m to 36 m depending on material being spread	337 kg	\$8799

## OPTIONS:

MODEL	DESCRIPTION	WEIGHT	LIST PRICE
S500	922782 500 L / 130 gallon hopper extension	27 kg	\$699
L1000	935040 1000 L / 265 gallon hopper extension	57 kg	\$1319
927784	Hopper cover for spreaders without extensions or with S500 hopper extensions only	26 kg	\$815
927785	Hopper cover for spreaders with L1000 extensions	29 kg	\$970
	OM Omnia-Set Spreading Discs (pair) OM10-12, OM10-16, OM18-24	12.5 kg	PRICE ON REQUEST
1733010	Boundry spread deflector Left Hand Side	5 kg	\$249
931810	Rolling parking stand	24 kg	\$590

Weights indicated are base machine weight, not shipping weight

# SPOT & ATV SPRAYER



LG15EC



ATV25700

## 15 Gal. Spot Sprayer

- \* 15 Gal. (U.S.) corrosion resistant polyethylene tank
- \* Full drain out capabilities with molded in drain port, cap & tether
- \* Large sump pickup
- \* 5" fill lid with tether
- \* 12 volt (demand) diaphragm 1.0 GPM 35 PSI pump
- \* 18" lever handgun with adjustable nozzle with 15 ft. of hose
- \* Max. horizontal throw 25 ft.
- \* Max. vertical throw 12 ft.

## 25 Gal. ATV Sprayer with Boom

- \* 25 Gal. (U.S.) corrosion resistant polyethylene tank
- \* Universal ATV mounting brackets
- \* Full drain out capabilities with molded-in drain port, cap & tether.
- \* 12 volt diaphragm demand style pump, 2.1 GPM. Pressure range 0 – 60 PSI
- \* Adjustable Pressure
- \* Pressure Gauge
- \* 18" Handgun with adjustable nozzle & 15 ft. of hose
- \* 7 Nozzle, 3 section folding boom 140" spray coverage Includes nozzles and screens

MODEL	DESCRIPTION	WEIGHT	LIST PRICE
LG15EC	15 gal. spot sprayer with hand gun & 15 ft. hose	18 lbs.	\$149
ATV25700	25 gal. ATV sprayer with 7 nozzle 3 section boom (140") with hand gun & 15 ft. hose	66 lbs.	\$520

# ESTATE SPRAYERS

## Tow Type



ATVTS6012V



TR30EX



TR40EX

- \* Measured in U.S. gallon / litres
- \* Corrosion resistant polyethylene tanks
- \* Lower tank profile for improved stability
- \* Full drain out capability with molded in drain port, cap & tether
- \* Full length drain sump
- \* Large pickup sump
- \* 5" fill lid with tether
- \* Both gallon (US) and litre fluid volume indicator
- \* 30 gallon includes lever handgun with adjustable nozzle and 15ft of hose
- \* 40 & 60 gal. includes deluxe pistol grip handgun with adjustable nozzle and 25ft of hose
- \* 30 & 40 gallon: 12 volt 2.1 gpm, 60 psi diaphragm pump
- \* 60 gal. 12 volt 3.8 gpm, 45 psi diaphragm pump
- \* "On-Off" Switch
- \* Includes spray boom (includes nozzles and screens):
  - 30 gallon, 2 nozzle 80" coverage
  - 40 gallon, 5 nozzle 100" coverage
  - 60 gallon, 7 nozzle 140" coverage

MODEL	DESCRIPTION	WEIGHT	LIST PRICE
TR30EX	30 gallon, 2 nozzle, 80" spray coverage 12V pump with 13" pneumatic tires	62 lbs.	\$479
TR40EX	40 gallon, 5 nozzle, 100" spray coverage 12V pump with 15/600 x 6 pneumatic tires	205 lbs.	\$949
ATVTS6012V	60 gallon, 7 nozzle, 140" spray coverage 12V pump, 18 x 9.5 x 8 pneumatic tires	295 lbs.	\$1499

Weights indicated are base machine weight, not shipping weight

# ATV & UTV SPRAYERS



- \* Corrosion resistant polyethylene tanks
- \* Lower tank profile for improved stability
- \* Full drain out capability with molded in drain port, cap & tether
- \* Full length drain sump
- \* Large pickup sump
- \* 5" fill lid with tether
- \* Both gallon (US) and litre fluid volume indicator
- \* Includes 5 nozzle, 100" spraying width, 3 section folding boom
- \* Includes deluxe pistol grip handgun with adjustable nozzle and 25 ft. of hose
- \* 12 volt, 2.1 gpm, 45 psi diaphragm pump
- \* Pressure gauge - adjustable pressure
- \* "On-Off" switch
- \* Steel skid type frame assembly

MODEL	DESCRIPTION	WEIGHT	LIST PRICE
UTL405	40 gal. UTV with 5 nozzle, 3 section boom 12 volt, 2.1 GPM pump. Mounts in rear box	117 lbs.	\$859

# SPRAYER

## 3 Pt. Hitch



40 gal. Cat. I, 3 Pt. sprayer for sub-compact and compact tractors for the application of pesticides, herbicides, insecticides or fungicides. Four nozzle boom with 120" spray coverage, 3 section boom features break-away hinges for transport or striking objects such as trees or post when spraying.

- \* 40 U.S. gallon polyethylene tank
- \* 12 volt diaphragm demand style pump  
2.1 gpm, 0-60 psi
- \* Break away hinges on boom
- \* 4 nozzle, 3 section Fold Behind Boom
- \* 120" spray coverage
- \* Deluxe pistol grip handgun with 15 feet of hose
- \* Pressure gauge
- \* 8 ft. lead wire with remote switch
- \* Cat. I, 3 Pt. hitch

MODEL	DESCRIPTION	WEIGHT	LIST PRICE
LG403PT12V	40 gal. US 3 Pt hitch sprayer 12V pump, 120" spray coverage	80 lbs.	\$519

# SPRAYER

## 3 Pt. Hitch



LG603PT

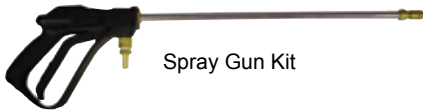

Spray Gun Kit



Pump

60 Gal. (U.S.) Cat. I 3 Pt hitch sprayer for compact tractors for the application of pesticides, herbicides, insecticides or fungicides. 3 section, 7 nozzle boom, fold behind, coverage 140" features break-away hinges on boom.

- \* 60 U.S. Gallon Polyethylene tank
- \* 7 Nozzle, 3 section fold behind boom
- \* Comes with TP8002VP Spray tips
- \* Break-Away Hinge on Boom
- \* 140" Spray Coverage
- \* 6 Roller Ni-Resist Pump with PTO Coupler
- \* Deluxe pistol Grip Hand gun with 25' of hose
- \* Single Manual Lever Valve Boom Control
- \* Relief Valve for Pressure Adjustment
- \* Pressure Gauge

MODEL	DESCRIPTION	WEIGHT	LIST PRICE
LG603PT	60 gal. US 3 Pt hitch sprayer with 6 roller Ni-Resist PTO pump	265 lbs.	\$1599

# SPRAYER FOAM MARKERS

*TrailLine*



TJEV24



TJ15G



TJ1G

A foam marker can be a simple solution to mark your sprayed area through deposits of balls or ribbons of foam. It's the most common and economical way to avoid over or under application of crop protection chemicals. Kits include a 12 volt compressor, a solution tank, control box, and all the parts necessary for installation on any type of spraying equipment.

- \* **Control box with electrical switch and safety fuse to direct foam to either side**
- \* **6' power cable**
- \* **15' compressor cable**

MODEL	DESCRIPTION	WEIGHT	LIST PRICE
TJEV24	6.4 Gal. poly tank, 108' poly 6 x 4 air/liquid tube covered by a flexible sheathing. 6" vertical foam drop nozzles with adjustable supports and diffuser bells.	41 lbs.	\$989
TJ15G	15 Gal. poly tank, 118' poly 6 x 4 liquid and 6 x 8 air tube covered with a soft sheathing, horizontal foam nozzles complete with new compact style angular diffuser bells and adjustable supports.	50 lbs.	\$1275
TJ1G	ATV sprayer foam marker, includes 1 Gal. tank, 2 foam outputs, 2 x 6' of tubing, remote switch control	16 lbs.	\$585

# ATV - UTILITY VEHICLE *Tufline* Attachments



## ATV DISC

Designed to work behind larger ATV's (450cc & up) and utility vehicles. This heavy duty ATV disc is ideal for soil preparation and ground breaking.

- \* Heavy duty 2" square tube frame
- \* 16" notched disc blades
- \* Adjustable gang angle
- \* 1" square axle shafts with sealed ball bearings
- \* 7-1/2" blade spacing
- \* Ratchet turnbuckle height adjustment
- \* Pneumatic tires on 8" rims
- \* 1-7/8" ball hitch

MODEL	DESCRIPTION	WEIGHT	LIST PRICE
ATVD7816-2	52" working width ATV disc (8) 16" disc blades	347 lbs.	\$1329
ATVD71016	64" working width ATV disc (10) 16" disc blades	498 lbs.	\$1729

## ATV OFFSET DISC



For 600 cc ATV's and larger and compact tractors. Available in 42", 48" & 56" working widths. Comes with 16" notched disc blades, with 9" blade spacing on dual disc gangs which creates a more aggressive & deeper cut. Tufline has developed a unique side draft and disc pressure adjustment system that keeps the unit tracking behind power unit.

- \* Heavy duty 3" square tube frame
- \* Adjustable angles for each gang
- \* Rated for 600cc ATV & above
- \* 9" blade spacing
- \* 16" notched disc blades
- \* 1 7/8" ball hitch

MODEL	DESCRIPTION	# BLADES	WEIGHT	LIST PRICE
UTD91016	42" Cutting Width	10	528 lbs.	\$2079
UTD91216	48" Cutting Width	12	564 lbs.	\$2179
UTD91416	56" Cutting Width	14	605 lbs.	\$2279



# ATV - UTILITY VEHICLE *Tufline*

## Attachments



Tufline's Flip Discs are an economical choice for use with ATV's 250 cc to 400 cc and small garden tractors.

- \* Formed tube steel main frame
- \* 52" cutting width
- \* Eight 16" notched disc blades
- \* 7-1/2" blade spacing
- \* 1" square hi-strength gang axle
- \* Weight tray for added weight when needed
- \* Cast iron friction bearings with grease fittings offer long life
- \* 1-7/8" ball hitch
- \* Two 4.10 - 6 pneumatic transport tires

MODEL	DESCRIPTION	# BLADES	WEIGHT	LIST PRICE
ATVFD7816	52" Flip Disc	8	245 lbs.	\$929

## ATV LAND PLANE



The Monroe Tufline ATV Land Plane is designed to be pulled by larger ATV's, UTV's and small compact tractors. Available in 2 working widths, 4' and 5'. Dual angled moldboards for maximum smoothing of gravel driveways, landscaping etc. Ratchet height adjustment, replacable cutting edges, pneumatic tires and a 1-7/8" ball hitch.

MODEL	DESCRIPTION	WEIGHT	LIST PRICE
ATVLP48	48" Working width	365 lbs.	\$1529
ATVLP60	60" Working width	415 lbs.	\$1579

# ATV - UTILITY VEHICLE *Tufline*

## Attachments

### ATV GRADER / SCRAPER BLADES

- \* Angle adjustment, left or right
- \* Moldboard height 15"
- \* Pneumatic tires on 8" rims
- \* 1-7/8" ball hitch



MODEL	DESCRIPTION	WEIGHT	LIST PRICE
ATVG48	4' (48")	215 lbs.	\$939
ATVG60	5' (60")	230 lbs.	\$979

### ATV BOX SCRAPER

- \* Manual lift lever for height adjustment
- \* 1/8" thick plate box frame
- \* Pneumatic tires on 8" rims
- \* 1-7/8" ball hitch



MODEL	DESCRIPTION	WEIGHT	LIST PRICE
ATVB48	4' (48") Box blade	205 lbs.	\$939

### ATV LANDSCAPE RAKE

- \* Manual lift lever for height adjustment
- \* 15" spring steel rake tines, mounted on 1" centers
- \* Pneumatic tires on 8" rims
- \* 1-7/8" ball hitch



MODEL	DESCRIPTION	WEIGHT	LIST PRICE
ATVLR48	4' (48") Landscape rake	192 lbs.	\$949
ATVLR60	5' (60") Landscape rake	203 lbs.	\$1019
ATVLR72	6' (72") Landscape rake	235 lbs.	\$1049

# CHAIN HARROWS

## Hackett Harrows



HACKETT HARROWS are designed to cover all applications from large farms to smaller hobby farms and equestrian venues. The Hackett Harrow is ideal for all types of ground work, by improving ground conditions by removing thatch, breaking up clods, working in fertilizer and breaking up and leveling soil, in established pastures, paddocks, park lands, small acreages, race tracks and horse arenas. The Hackett Harrows is manufactured in the U.K. from high quality steel, which ensures that the harrow is extremely strong with high resistance to wear. Harrows are available in 4 ft. 8 ft. 12 ft. and 16 ft. widths, x 4 ft. or 8 ft. long.

- \* Tine size 1/2" x 3-1/2"
- \* Sixty tines per 4 foot section
- \* High quality, high carbon steel tines
- \* Heat treated at optimum temperatures to ensure high resistance to wear

### PULL TYPE HARROW SETS COMPLETE WITH DRAWBAR

WIDTH X LENGTH	CONTENTS	WEIGHT	LIST PRICE
4' x 4'	1-CC044 & 1-DB04U	105 lbs.	\$254
8' x 4'	2-CC044 & 1-DB08U	203 lbs.	\$459
12' x 4'	3-CC044 & 1-DB12U	301 lbs.	\$684
16' x 4'	4-CC044 & 1-DB16U	402 lbs.	\$959
4' x 8'	2-CC044 & 1-DB04U	179 lbs.	\$409
8' x 8'	4-CC044 & 1-DB08U	351 lbs.	\$769
12' x 8'	6-CC044 & 1-DB12U	523 lbs.	\$1149
16' X 8'	8-CC044 & 1-DB16U	698 lbs.	\$1579

# MANURE SPREADER PULL TYPE



The Fimco 25 bushel ground drive manure spreader is ideal for the small farmers with cattle, horses, sheep, goats, etc. that needs to move maure and spread it on pastures. Movable apron cjain with slats, moves material to rear of box where a beater with paddles spreads the manure. Can be pulled by a small lawn & garden or compact tractor or ATV / UTV.

- \* 25 bushel capacity
- \* Chain driven Mechanisms
- \* Handy lever controls to engage apron chain & beater
- \* Corrosion resistant bed floor
- \* Overall width 48" x length 9' 9" x height 31"
- \* Box dimension 72" L x 28" W x 18-1/2" H
- \* Ground drive tire size 6.00 x 12 with Ag. tread
- \* Includes tongue jack

MODEL	DESCRIPTION	WEIGHT	PRICE
MS25BU	Manure spreader ground drive	464 lbs.	\$3440

# ROCK RAKES



PWD10



WD6

Houle Fabrication offers 4 models of rock rakes, two 3 Pt. hitch and three pull types, 540 PTO RPM, for windrowing rocks for easier pickup. The most efficient rock rake on the market because of the many features that make them easy to use and to move. Made in CANADA.

MODEL	DESCRIPTION	WEIGHT	LIST PRICE
<b>WD6</b>	5' 2" working width, Cat II, 3 Pt. hitch 540 RPM PTO, slip clutch PTO with 2-16.5" x 6.5" pneumatic tires. Replaceable and reversible teeth. Sealed transfer case. Recommended HP 40-60 HP	1150 lbs	\$9669
<b>WD10B</b>	10' working width, 3 Pt. Cat. II, two 18.5 x 8.5 tires which swivel 360°, maintains balance, replaceable & reversible teeth, sealed Transfer case for longer lasting #100 drive chain, Slip clutch PTO. Recommended HP 65-125 HP, recommended speed 4-6 kmh.	1850 lbs.	\$12,479
<b>PWD10</b>	10' working width, pull type with 11L x 15 transport tires, replaceable and reversible teeth, adjustable flotation system provides protection against breakage & obstacles. Includes lift hydraulic cylinder & hoses. #100 Drive chain. Slip clutch PTO. Recommended HP 50-125 HP. Recommended speed 4-6 kmh.	2400 lbs.	\$15,159
<b>SRR15</b>	15' working width, pull type with 11L x 15 transport tires, comes with Manual transport kit. Replaceable and reversible teeth, adjustable flotation system provides protection against breakage & obstacles. Includes lift hydraulic cylinder & hoses. Slip clutch PTO, #100 drive chain. Recommended HP 65 + HP, recommended speed 4-6 kmh.	3600 lbs.	\$22,279
<b>SWD15</b>	15' working width, pull type with 11L x 15 transport tires, comes with Hydraulic transport kit. Replaceable and reversible teeth, adjustable flotation system provides protection against breakage & obstacles. Includes lift & transport hydraulic cylinders & hoses. Slip clutch PTO, #100 drive chain. Recommended HP 65 + HP, recommended speed 4-6 kmh.	4700 lbs	\$23,999

15 ft. hydraulic driven models now available in SRR15 and SWD15 models.

F.O.B. St. Germain PQ

Weights indicated are base machine weight, not shipping weight

# TREE SHEARS



S. Houle Fabrication offers two tree shears, a 8" and a 16" cutting capabilities. Available in tractor loader mount or skid steer mount.

<b>8" TREE SHEAR</b>	
<b>TS08 LOADER MOUNT \$7429</b>	<b>TS08SS SKID STEER MOUNT \$7469</b>
<ul style="list-style-type: none"> <li>* Cuts up to 8" capacity</li> <li>* Designed to trim and cut trees and limbs in tight spaces and near fence lines.</li> <li>* The cylinder's thrust provides each blade with 60,000 PSI</li> <li>* For tractors, skid steers and tele-handlers minimum 60 HP with hydraulic flow 75-95 LM/14-19GPM @ 2700-3000 PSI.</li> <li>* 6" x 5" hydraulic cylinder for scissor action blades</li> <li>* 3" x 11' hydraulic cylinder for rotation cylinder</li> <li>* Cutter head rotates 110 degrees</li> <li>* Blades are made of RT-400 Steel</li> <li>* A single electro-hydraulic valve allows you to switch from one hydraulic cylinder to the other</li> <li>* Tractor loader mount requires optional loader mounting brackets., extra.</li> <li>* Skid steer mount comes with universal skid steer mounting bracket</li> <li>* Weight 987 lbs. (448kg)</li> </ul>	
<b>16" TREE SHEAR</b>	
<b>TS16 TRACTOR LOADER MOUNT \$10,399</b>	<b>TS16SS SKID STEER MOUNT \$10,459</b>
<ul style="list-style-type: none"> <li>* Cuts up to 16" Capacity</li> <li>* Cutting power up to 85,000 PSI</li> <li>* Requires a minimum of 75 HP tractor, skid steer or tele-handler with minimum hydraulic flow 75-95 LM (20-25 GPM) @ 2700 – 3000 PSI</li> <li>* RT-400 Steel frame and a blade with an RT-400 steel cutting edge that is also reinforced to eliminate distortion</li> <li>* Single blade eliminates center cut splinters</li> <li>* Blade moves from left to right for better operator visibility</li> <li>* Concave jaw design</li> <li>* 3" x 8" hydraulic tilt cylinder rotates cutter head 110 degrees</li> <li>* Massive 3" blade pivot pin provides unmatched rotational strength.</li> <li>* All pivot points are greaseable.</li> <li>* A single electro-hydraulic valve allows you to switch from one cylinder to the other</li> <li>* Tractor loader mount requires optional loader mounting brackets., extra.</li> <li>* Skid steer mount comes with universal skid steer mounting bracket</li> <li>* Weight 1550 lbs. (705kg)</li> </ul>	

### **OPTIONS:**

#### **DESCRIPTION**

CA011604E02  
31031

Brush Guard for TS16  
High Flow Solenoid 3500 + PSI

#### **LIST PRICE**

\$679  
\$469

**F.O.B. St. Germain, PQ**

# TREE SHEARS



TS08



TS16  
Shown with optional  
brush guard

F.O.B. St. German, PQ

Weights indicated are base machine weight, not shipping weight

# H&S

# Innovation + Technology + The Market Leader = H&S Forage Boxes!

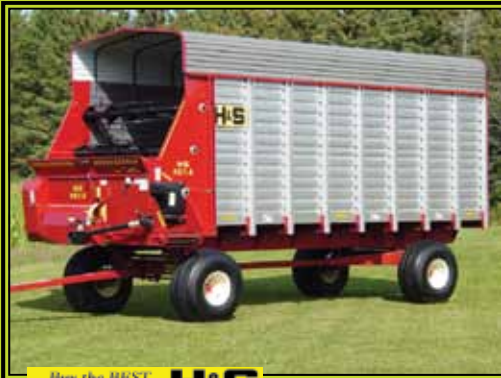

### XTRACAP Forage Boxes Feature:

- \*More Cross Members
- \*New Color Scheme
- \*More Capacity
- \*More Uprights
- \*More Height

Buy the BEST **H&S**  
BUY



**"SUPER DUTY"** Forage Boxes are available  
w/ Electric-Over-Hydraulic Cab Controls!

**H&S**  
Wide  
Body  
"The Only  
Box with  
Patented  
Center  
Drive"



ONLY AVAILABLE THROUGH  
STOCKING DEALERS



# TREE SAW



TS100 Model Shown



TSG200 Model Shown

The BROWN TREESAWS are designed to be rugged machines that can handle selective clearing of wood lots, fence rows, food plots, ATV/bike trails etc. the heavy construction is tough enough to cut heavy brush and trees up to 8" in diameter. The balanced blade keeps vibration to a minimum. The TS100 comes with a rigid brush bar for controlling brush and trees as you cut them. The TSG200 comes with a hydraulic grapple for moving brush and cut trees after cutting. Both units include a brush guard to protect operator.

- \* **Minimum HP required 35 HP**
- \* **Cat. 1 3 Pt. Hitch**
- \* **Height of cut: ground level**
- \* **All welded construction**
- \* **Gear Box Ratio 1: 1.5**
- \* **540 RPM PTO**
- \* **30" Blade with replaceable carbide teeth**

MODEL	DESCRIPTION	WEIGHT	LIST PRICE
TS100	TREESAWS with brush guard	850 lbs.	\$6469
TSG200	TREESAWS with hydraulic grapple & brush guard (includes hydraulic hose)	1050 lbs.	\$7799

# LOGGING WINCHES

Fransgård



The **FRANSGÅRD** winch was designed for log skidding in wood lot applications. They are available in 5 models according to pulling capacity. They range from 6600 lbs to 14,300 lbs pulling capability. The overall dimensions of the winch are specifically designed to enable easier access in narrow passages. The winch can also be used for log "dozing" and land leveling making the Fransgård winch a versatile piece of equipment.

- \* Winches are available in 5 models for 3 Pt. hitch tractors.
- \* Standard with slip clutch protection
- \* Standard cable with one hook included
- \* Cable is pre-installed on wire drum
- \* HP Requirements: 25-80
- \* Protective screen guard included
- \* Extra supports on the top pulley provide additional resistance when pulling heavier logs
- \* A cable drum tension bracket prevents unspooling of the cable when pulling the cable out

MODEL	PULL CAP.	WEIGHT	TRACTOR HP REQ'D	CABLE LENGTH	CABLE DIA.	LIST PRICE
V3004	6600 lbs	385 lbs.	25	133'	5/16"	\$3599
V3507	7700 lbs	408 lbs.	25	133'	5/16"	\$4099
V4000	8800 lbs	550 lbs.	40	167'	3/8"	\$4899
V5000	11,000 lbs	667 lbs.	40	167'	3/8"	\$5799
V6500	14,300 lbs	880 lbs.	80	167'	7/16"	\$6999

**CAUTION:** Timber winches are mounted very close to the tractor for maximum stability, therefore PTO length is critical. Stock length shaft supplied may require shortening to suit tractor. Operator should ensure that the PTO is never operated at over a 30 degree angle. Three point hitch linkage must have lower setting adjusted so winch does not dig into soft ground pulling the or breaking the PTO shaft. There is no warranty on PTO shafts and knuckles broken or bent under the circumstances listed above. Never transport logs hooked to top of winch by cable, always use chains hooked to transport bar which gives a lower center of gravity.

**NOTE :** Please review owners manual as there are specific operating and maintenance instructions - cables are considered a wearing part and are not covered by warranty.

Not available in Quebec

# LOGGING WINCH Accessories

Fransgård



1582



1562



1525/1546/1556



1586/1588



1584



1595/1596



1593

MODEL	DESCRIPTION	LIST PRICE
1562	End hook for cable	\$17
1582	Choker/Slider	\$32
1584	Choker chain 7' silver (for use w/V3004 & V3507. Work load 2200lbs/1000kg)	\$54
1586	Choker chain heavy duty 7' red (for use with V4000 & V6500 Work load 6615 lbs/3000kg)	\$93
1588	Choker chain heavy duty 10' red (for use with V4000 & V6500 Work load 6615 lbs/3000kg)	\$118
1593	Middle Pulley for V3004 and V3507	\$138
1595	Distance Pulley - 4000 kg / 8800 lbs.	\$449
1596	Distance Pulley - 13000 kg / 28600 lbs.	\$1125

Weights indicated are base machine weight, not shipping weight

# LOG SPLITTER

Engine Driven  
Towable



TL23357



TL2HV25



TL23353

# LOG SPLITTER

## Engine Driven

## Towable



The new TERRALINE of engine driven, towable log splitters include three models, 22 ton, 25 ton, vertical and horizontal split, and a 25 ton dual action horizontal splitter. All units come with Hi-speed (45 MPH) tires, 2" ball coupler.

MODEL	DESCRIPTION	WEIGHT	LIST PRICE
TL23357	22 Ton, 208cc LCT Engine <b>VERTICAL OR HORIZONTAL SPLITTER</b> 11 GPM 2 Stage Gear Pump, 4" X 23" Hydraulic Cylinder Oil Capacity 2.64 Gallon. Maximum Splitting Length 24". Maximum Splitting Diameter 14" 7" Hardened Steel Wedge, Auto Return Hydraulic Valve 16" x 6.5" Pneumatic Tires, (NO Fenders)	343 lbs	\$1695
TL2HV25	25 Ton, 208cc LCT Engine <b>VERTICAL OR HORIZONTAL SPLITTER</b> 11 GPM 2 Stage Gear Pump, 4.5" X 24" Hydraulic Cylinder Oil Capacity 6.5 Gallon. Max Splitting Length 26" 8" Hardened Steel Wedge, Auto Return Hydraulic Valve 16" x 6.5" Pneumatic Tires	485 lbs	\$1899
TL23353	25 Ton, 208cc LCT Engine <b>DUAL ACTION HORIZONTAL SPLITTER</b> 11 GPM 2 Stage Gear Pump, 4.5" X 24" Hydraulic Cylinder Oil Capacity 2.64 Gallon. Max Splitting Length 24". Max. Dia. 16" Splitting Force forward: 25 ton max Splitting Force return: 18.5 ton Splitting Speed forward: 9 sec Splitting Speed return: 7 sec 7.5" Hardened Steel Wedge, Auto Return Hydraulic Valve 16" x 6.5" Pneumatic Tires	430 lbs	\$1969

### OPTIONS:

MODEL	DESCRIPTION	LIST PRICE
TL4XW-ES22	4-way cross wedge for TL23357	\$85
TL4XW-DS25	4-way cross wedge for TL2HV25	\$85

# LOG SPLITTER

## 3 Pt. Hitch



The new TERRALINE of log splitters include this 3 point hitch model. Attaches to Cat. I 3 Pt. Hitch tractors, horizontal Split, 14 ton capacity (depending on hydraulic output of tractor). Optional stand and 4 way cross wedge is available. Does not include hydraulic hoses (2) or hydraulic coupler plugs to tractor.

- \* Cat. I 3 Pt. Hitch
- \* 14 ton capacity
- \* Recommended 11 GPM from tractor
- \* Splits in horizontal position
- \* Maximum log length 24"
- \* Cylinder size 4" x 24"
- \* Pressure relief setting 2500 PSI
- \* 7.87" Hardened steel wedge

MODEL	DESCRIPTION	WEIGHT	LIST PRICE
TL23303	3 Pt. Hitch Cat. I 14 ton capacity	251 lbs.	\$959

### OPTIONS:

MODEL	DESCRIPTION	LIST PRICE
TL4XW-TP14	4-way cross wedge	\$85

# STUMP GRINDERS

## 3 Pt. Hitch



SureFoot Stabilizer Bar

This **WORKSAVER** economical and efficient PTO powered stump grinder makes stump removal fast & easy. The operator easily controls the stump grinder from the comfort of their tractor seat.

- \* **Maneuverable - goes anywhere a tractor can.**
- \* **Cutting wheel design provides a smoother cutting action.**
- \* **Durable carbide-tipped cutting teeth are economical and easy to replace.**
- \* **SUREFOOT stabilizer bar provides solid footing during operation.**
- \* **Rubber deflector helps control chips during grinding.**
- \* **Hardened bushings used in major pivot points for increased reliability.**

MODEL	SG26 (3 Pt)	SG36 (3 Pt)
LIST PRICE	\$6999	\$7999
Hitch	Cat. 1	Cat. 1 and 2
Overall Length	75"	80"
PTO Driveline	Series 5	Series 6
Driveline Protection	Slip Clutch	Slip Clutch
Gearbox Rating	60 HP	100 HP
Cutting Wheel Thickness	3/4"	3/4"
Cutting Wheel Diameter	26"	36"
# Of teeth	30	39
Cutting Ht Above Ground	18"	18"
Cutting Ht Below Ground	10"	10"
Max. Cut Depth Per Pass	5"	8"
Max. horizontal cut	28"	33"
Swing Arc	45°	45°
HP Requirement	22-50	45-100
Weight	660 lbs.	880 lbs.

### OPTIONS:

MODEL	DESCRIPTION	LIST PRICE
811600	Box of 25 replacement carbide teeth with bolts and washers	\$285

Weights indicated are base machine weight, not shipping weight

# 6" CHIPPER



The Bushmaster PTO driven chipper saves time and labour by reducing humus material to a valuable mulch. Ideal for nurseries, contractors, small municipalities and golf courses. The Bushmaster PTO driven chipper comes complete with:

- \* HP Requirements: 30-50, 540 RPM
- \* Variable speed power feed 70 or 45 FPM
- \* Continuous chipping capacity of up to 6"
- \* Power feed on/off control bar
- \* Cat. 1 3 Pt. hitch
- \* Drum style chipping wheel gives sure handled feeding
- \* Easy access to belts and chipper knives
- \* Built in high volume blower with optional 15" extension pipe
- \* Heavy duty shielded PTO shaft (1-3/8" ASAE Cat. 4)

MODEL	CHIPPING CAPACITY	# KNIVES	WEIGHT	LIST PRICE
BM6-800	6"	2	900 lbs.	\$9189

**OPTIONS:**

MODEL	DESCRIPTION	LIST PRICE
BM6-000	15" Blower pipe extension	\$179



# GRAPPLE RAKES

## Compact Tractors up to 40 HP



**WORKSAVER** grapple rakes for skid steer and tractor front loaders are ideal for loading logs, picking rocks, and orchard prunings. Can be used for raking and piling brush and other hard to handle materials. Skid steer models use "Universal attaching" system for quick convenient method of hook-up. Tractor front loader mounting brackets extra. Pin type or quick attach brackets available.

- \* Single grapple
- \* Single cylinder controls upper grapple
- \* Optional interfacing quick-attach bracket available to fit most John Deere, AGCO, Kubota, CNH, and other brands of loaders.
- \* The FLGR-4062S is used on OEM loaders that utilize the skid steer quick-attach system

MODEL	APPLICATION	WIDTH	WEIGHT	LIST PRICE
FLGR4062	Front Loader	60"	359 lbs.	\$2269
FLGR4062S	Front Loader with skid steer quick-attach system	60"	355 lbs.	\$2429
NOT FOR USE ON SKID STEER LOADERS				

# GRAPPLE RAKES

## Tractors / Skid Steer



**WORKSAVER** grapple rakes for skid steer and tractor front loaders are ideal for loading logs, picking rocks, and orchard prunings. Can be used for raking and piling brush and other hard to handle materials. The split top design provided dual upper grapples for picking up brush and other debris while leaving the dirt behind. Skid steer models use “Universal attaching” system for quick convenient method of hook-up. Tractor front loader mounting brackets extra. Pin type or quick attach brackets available.

- \* **Two working widths 62” and 77” with 4 grapple tines**
- \* **Tine spacing 15” center to center**
- \* **Grapple opening 50”**
- \* **Grapple depth 25”**
- \* **Reinforced tubes welded between lower tines for added strength**
- \* **Includes hydraulic cylinders, less hoses**

MODEL	APPLICATION	WIDTH	WEIGHT	LIST PRICE
FLGR262	Front Loader	62”	786 lbs.	\$3959
FLGR277	Front Loader	77”	966 lbs.	\$4539
SSGR262	Skid Steer	62”	784 lbs.	\$4259
SSGR277	Skid Steer	77”	964 lbs.	\$4819

**OPTIONS:**

MODEL	DESCRIPTION	LIST PRICE
811395	Parking Stand Kit, 26 lbs Allows upright storage and easy hook up on hard surfaces	\$225

# GRAPPLES FOR ROCK BUCKETS

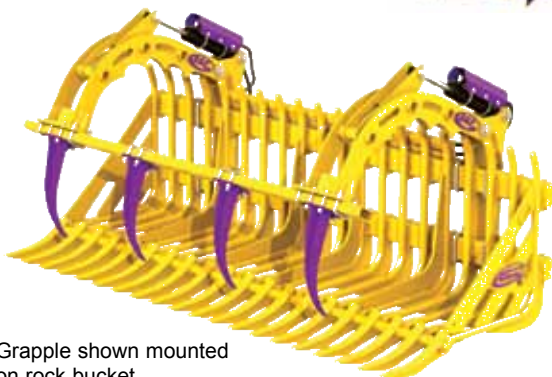

Grapple shown mounted on rock bucket

Houle provides two models of Grapple attachments for their **rock buckets** depending on the model. Units bolt on to buckets, and include two 2-1/2" x 18" hydraulic cylinders, (less hydraulic hoses to tractor), & four replaceable hardened steel teeth. Units are easily detached from bucket when not required.

MODEL	DESCRIPTION	WEIGHT	LIST PRICE
GP10	Fits 6' to 9' B & HB Rock Buckets	625 lbs.	\$2389
SGP10	Fits 7' to 9' SHB Rock Buckets	700 lbs.	\$3599



SSQA150



A0600  
Alo Loaders

## U-BOLT ON QUICK ATTACH BRACKETS

S. Houle Fabrication U-Bolt-On quick attach brackets are manufactured extra heavy duty to withstand the punishment of digging and picking stones and rocks. Designed and built to allow bucket more roll back.

MODEL	DESCRIPTION	WEIGHT	LIST PRICE
UA100	U-Bolt-On pin type loader brackets (pair)	70 lbs.	\$339
SSQA150	U-Bolt-On universal skid steer quick attach bracket	105 lbs.	\$499
A0600	U-Bolt-On quick attach brackets for ALO loaders	105 lbs.	\$499

Also available many more brackets to fit Allied (Farm King), Alo, Case IH, JD, FNH, Cat, Kubota, MF, etc. Check with your local dealer for the availability of brackets for your loader.

Weights indicated are base machine weight, not shipping weight

# ROCK BUCKET



S. Houle rock buckets are unique on the market, with unmatched tip design and high quality steel tines, we ensure you have the most robust tool to accomplish the work you need to do. Our tips are specifically designed to support maximum weight up to 3 times what or competition can offer. Their specially designed profile offers a stopper that allows more volume capacity by keeping rocks and stones from tumbling out. We have such confidence in our product we offer a limited lifetime warranty on tips. We offer 4 different tine sizes of rock buckets in various working widths. All rock buckets are priced less loader mounting brackets.

- \* Each tooth made from spring steel.
- \* Priced less mounting brackets

## BB Series

STANDARD ROCK BUCKET 1.125" TOOTH DIA. X 2.5" SPACING TENSILE STRENGTH - 83,077 Lbs.						
MODEL	WORKING WIDTH	DEPTH	HEIGHT	# OF TEETH	WEIGHT (LBS.)	LIST PRICE
BB4W	4' / 48"	37"	24"	14	397	\$1909
BB5W	5' / 60"	37"	24"	17	477	\$2089
BB6W	6' / 72"	37"	24"	21	583	\$2339
BB7W	7' / 84"	37"	24"	24	663	\$2459

## B Series

STANDARD ROCK BUCKET 1.25" TOOTH DIA. X 2.5" SPACING TENSILE STRENGTH - 112,500 Lbs.						
MODEL	WORKING WIDTH	DEPTH	HEIGHT	# OF TEETH	WEIGHT (LBS.)	LIST PRICE
B6	6' / 72"	42"	24"	19	760	\$2799
B7	7' / 84"	42"	24"	22	875	\$3039
B8	8' / 96"	42"	24"	25	990	\$3369

Call your local dealer for the availability and pricing on heavy duty S. Houle loader quick attach brackets for your loader.

# ROCK BUCKET



S. Houle rock buckets are unique on the market, with unmatched tip design and high quality steel tines, we ensure you have the most robust tool to accomplish the work you need to do. Our tips are specifically designed to support maximum weight up to 3 times what or competition can offer. Their specially designed profile offers a stopper that allows more volume capacity by keeping rocks and stones from tumbling out. We have such confidence in our product we offer a limited lifetime warranty on tips. HB Series is intended for use with tractors ranging from 85 to 200 HP. SHB Series is built for industrial loaders and large backhoe loaders. All rock buckets are priced less loader mounting brackets.

## HB Series

HEAVY DUTY ROCK BUCKET 1.5" TOOTH DIA. X 3" SPACING TENSILE STRENGTH - 135,000 Lbs.						
MODEL	WORKING		HEIGHT	# OF TEETH	WEIGHT (LBS.)	LIST PRICE
	WIDTH	DEPTH				
HB5	5' / 60"	42"	24"	14	705	\$2849
HB6	6' / 72"	42"	24"	16	820	\$3119
HB7	7' / 84"	42"	24"	17	990	\$3369
HB8	8' / 96"	42"	24"	22	1110	\$3619
HB9	9' / 108"	42"	24"	25	1375	\$3859

## SHB Series

SUPER HEAVY DUTY ROCK BUCKET 1.75" TOOTH DIA. X 4" SPACING TENSILE STRENGTH - 157,500 Lbs.						
MODEL	WORKING		HEIGHT	# OF TEETH	WEIGHT (LBS.)	LIST PRICE
	WIDTH	DEPTH				
SHB8	8' / 96"	42"	24"	18	2075	\$7329
SHB9	9' / 108"	42"	24"	20	2205	\$7659

SHB Series require special loader mounting brackets. **Price on Request**

Call your local dealer for availability and pricing on heavy duty U-Bolt type quick attach brackets for your loader

# GRAPPLE BUCKET LOW PROFILE SKID STEER



Model LPSB



Model LPTG

WorkSaver's NEW Low Profile Grapple Buckets come in two different styles, Tine Bottom and Solid Bottom. Available in four models, all with a split grapple assembly with 2 hydraulic cylinders with cylinder guards to protect cylinders and hoses. These NEW Grapple Buckets are manufactured to attach to any skid steer with the "universal" skid steer quick attach mounting system. Comes with hydraulic hoses and "connect under pressure" flat faced couplers.

- \* 72" & 84" overall width
- \* Split grapple assembly
- \* Tine grapple has 7 1/2" spacing
- \* Scrap bucket cutting edge is pre-drilled to accept optional replaceable bevelled cutting edge
- \* Complete with "connect under pressure" flat faced couplers
- \* Two 2"x10" Hyd cylinders with cylinder guard protection
- \* Universal skid steer quick attach mounting bracket

MODEL	DESCRIPTION	WEIGHT (LBS.)	LIST PRICE
LPTG72	72" Low profile tine grapple bucket	820 lbs.	\$4319
LPTG84	84" Low profile tine grapple bucket	898 lbs.	\$4629
LPSB72	72" Low profile scrap grapple bucket	760 lbs.	\$4359
LPSB84	84" Low profile scrap grapple bucket	855 lbs.	\$4889

## OPTIONS: FOR LPSB72 OR LPSB84 SCRAP BUCKET

MODEL	DESCRIPTION	LIST PRICE
811790	3/4" x 8" x 72" reversible cutting edge & hardware	\$505
811870	3/4" x 8" x 84" reversible cutting edge & hardware	\$579

# MANURE FORKS



M/SG-72S



M/S-60S

The WorkSaver Manure Fork was designed for picking up manure, matted straw or other loose materials. Excellent for handling silage, units with upper grapple helps secure load during transport improving productivity. All units have forged cranked tines for extended service life. Units with upper grapple and skid steer mount are supplied with hydraulic hoses and connect under pressure couplers for ease of installation. Models with upper grapple have greasable pivot points for long life and cylinder pivot points utilize replaceable harden bushing to reduce wear.

- \* Available in 60" & 72" widths
- \* Available with or without upper grapple
- \* Overall depth 31" / 787mm
- \* Overall height 21.5" / 546mm
- \* Useable tine length 27" / 686mm
- \* Upper grapple width 34" / 864mm
- \* Tine spacing 7.5" / 190mm
- \* Number of tines 60" - 8, 72" - 10

Units come with Universal Skid Steer quick attach plate. Includes hydraulic hoses and flat face couplers.

MODEL	DESCRIPTION	WEIGHT	LIST PRICE
MS60S	Manure fork 60" wide	225 lbs.	\$1239
MSG60S	Manure fork 60" wide with upper grapple	405 lbs.	\$2899
MS72S	Manure fork 72" wide	270 lbs.	\$1339
MSG72S	Manure fork 72" wide with upper grapple	450 lbs.	\$3159

Units require Optional Bolt-on Quick Attach Brackets. To be ordered separately. Units with upper grapple come LESS hydraulic hoses & couplers.

MODEL	DESCRIPTION	WEIGHT	LIST PRICE
MS60U	Manure fork 60" wide	225 lbs.	\$1239
MSG60U	Manure fork 60" wide with upper grapple	375 lbs.	\$2509
MS72U	Manure fork 72" wide	270 lbs.	\$1339
MSG72U	Manure fork 72" wide with upper grapple	450 lbs.	\$2789

# PALLET FORKS

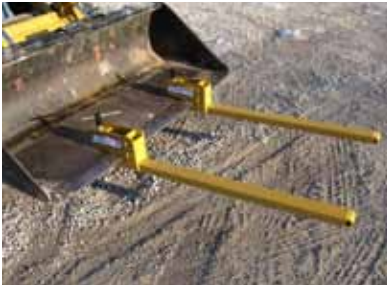

- \* **Clamp-On to material loader Bucket**
- \* **Available in three sizes**
- \* **No tools required to install**

MODEL	DESCRIPTION	WEIGHT	PRICE
BF1000	1000 lb capacity, 35" usable length, pair.	78 lbs.	\$479
BF2000	2000 lb capacity, 42" usable length, pair.	102 lbs.	\$549
BF4000	4000 lb capacity, 42" usable length, pair.	168 lbs.	\$879



- \* **1-1/4" x 4" solid forks with spring loaded toggle latch for positioning**
- \* **Skid steer mount units have step through design**

MODEL	DESCRIPTION	WEIGHT	LIST PRICE
SSPF442	Pallet forks 4000 lb. rated, 42" long to fit skid steer or tractor loaders with universal skid steer attach system	345 lbs.	\$1239
SSPF448	Pallet forks 4000 lb. rated, 48" long to fit skid steer or tractor loaders with universal skid steer attach system	359 lbs.	\$1239
PF448	Pallet forks 4000 lb. rated, 48" long to fit tractor loaders. Designed to mount to tractor loaders with centre to centre between arms up to 50" Optional interfacing quick attach brackets extra	438 lbs.	\$1249

Pallet forks available for John Deere 400/500 series loaders and loaders with GLOBAL / EURO attaching system



# COMPACT PALLET FORKS

## For 40 HP Tractors / Loaders



These newly designed compact pallet forks from WorkSaver incorporates many of the same durability features found in our larger units. These models utilize Class I forks (1" x 4" x 42") rated at 2,000 lbs. for the pair providing optimal lifting capacity. Spacing adjustment is easy with spring loaded latches allowing the operator to move the forks along the notched rail.

- \* **Class I solid steel alloy forks**
- \* **Forks are 1" x 4" x 42" rated @ 2000 lbs. / pair**
- \* **Rail style forks with spring loaded latches**
- \* **3 models available for tractors with loaders up to 40 HP**

MODEL	DESCRIPTION	WEIGHT	LIST PRICE
SSPF242	Pallet forks 2000 lb. rated to fit loaders with universal skid steer attaching systems	290 lbs.	\$939
FLPF2000	Pallet forks 2000 lb. rated to fit any compact tractor loader under 40HP accepting quick attach system Brackets extra (sold separately)	270 lbs.	\$999
JDPF2000	Pallet forks 2000 lb. rated to fit John Deere 200 / 300 Series with JD quick attach system	280 lbs.	\$1059

Weights indicated are base machine weight, not shipping weight

# COMBI-RAKE RV

## 3 Pt. Hitch

Fransgård



The Fransgard Basket type rake is designed to deliver fast and even drying of your crop of hay. The pickup tines are lowered into working position by centrifugal force and follow the terrain contour in a uniform fashion. This rake can both windrow or act as a tedder.

- \* Working width: Raking 9 ft  
Tedding 9 ft. 6 in
- \* Transport Width: 2.5m / 8 ft
- \* Working Speed: 10 to 15 km
- \* HP Requirement: 30 HP
- \* Number of tines 20
- \* Tires: Two 15 x 6.00
- \* CAT I, 3 Pt. hitch
- \* 540 RPM PTO with slip clutch

MODEL	DESCRIPTION	WORKING	WEIGHT	LIST PRICE
		WIDTH		
RV300	Rake / Tedder 3 Pt.	Raking 2.75m / 9 ft Tedding 2.90m / 9 ft. 6 in.	787 lbs.	\$6999

# FINGER WHEEL RAKES

## 3 Pt. Single Side

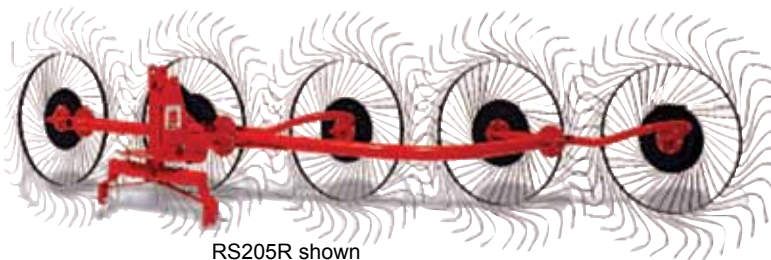

RS205R shown

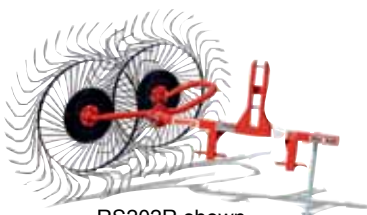

RS202R shown

For tractors from 30 HP engine and up. Category 1 or 2, 3 Pt. hitch. Finger rake wheels are mounted on molded steel hubs with tapered bearings. Lifts hay gently, and evenly from undulating terrain. May also be used for raking, turning or spreading swathes. Its fast working speed makes it possible to cover a large acreage quickly. Having no gears, chains or other drive components to wear out, the finger wheel rake is truly a low maintenance tool.

- \* **HP Requirements: 30-80**
- \* **Cat. 1 3 Pt. hitch**
- \* **Molded steel hubs with greasable tapered bearings**
- \* **May also be used for raking, turning or spreading swathes**
- \* **Lifts hay gently, even from undulating terrain**

MODEL	# WHEELS	MAXIMUM		
		WORKING WIDTH	WEIGHT	LIST PRICE
RS202R	2	4' 3"	194 lbs.	\$805
RS203R	3	6' 5"	291 lbs.	\$1189
RS204R	4	8' 6"	388 lbs.	\$1595
RS205R	5	11'	495 lbs.	\$1945
RS206R	6	12' 9"	602 lbs.	\$2325

Weights indicated are base machine weight, not shipping weight

# HAY HANDLING ATTACHMENTS FOR JOHN DEERE LOADERS & AL0 GLOBAL STYLE QUICK ATTACH LOADERS

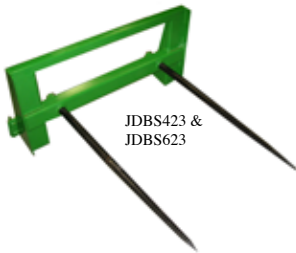

JDBS423 &  
JDBS623



JDBS412 & JDBS612

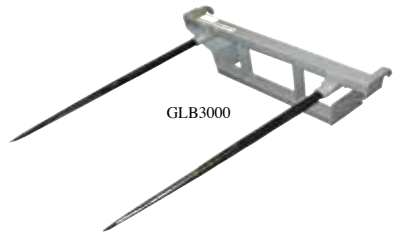

GLB3000



GLB2200

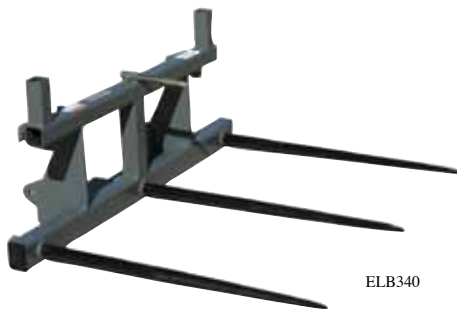

ELB340

# HAY HANDLING ATTACHMENTS FOR JOHN DEERE LOADERS & ALO GLOBAL STYLE QUICK ATTACH LOADERS



**For John Deere loaders**  
300,300CX,400X,410,420,430,440,460,520,521,540,541,542,553

MODEL	DESCRIPTION	WEIGHT	LIST PRICE
JDBS412	2200 lb. Single Loader Bale Spear 42" tapered forged spear with two 1" x 8-1/2" balance spikes	121 lbs.	\$669
JDBS423	3000 lb. Dual Bale Spear Two 42" forged tapered spears.	156 lbs.	\$849

**For John Deere loaders**  
620,640,720,721,725,726,740,741

MODEL	DESCRIPTION	WEIGHT	LIST PRICE
JDBS612	2200 lb. Single Bale Spear 42" tapered forged spear with two 1" x 8-1/2" balance spikes	176 lbs.	909
JDBS623	3000 lb. Dual Bale Spear Two 42" forged tapered spears, spaced 30" apart	196 lbs.	\$1049

**For Global/Euro Alo Quick Attach Loaders**

MODEL	DESCRIPTION	WEIGHT	LIST PRICE
GLB2200	2200 lb. Single Bale Spear 42" tapered forged spear with two 1" x 8-1/2" balance spikes	114 lbs.	\$619
GLB3000	3000 lb. Dual Bale Spear Two 42" forged tapered spears, spaced 30" apart	128 lbs.	\$739
ELB340	4000 lb. rated Triple Spear spaced 26" apart with usable length of 42" for large size square bales	200 lbs.	\$979

## OPTION

831095	Bolt-on Upright kit for handling two square bales.	32 lbs	\$139
--------	---	--------	-------

# HAY HANDLING ATTACHMENTS

## Bucket Mount



BBSF20



CBSF2000



CBSF3028

MODEL	DESCRIPTION	WEIGHT	LIST PRICE
BBSF20	2,000 Lb. Bolt-on Bucket Bale Spear Single tapered forged tine for use with tight center bales	68 lbs.	\$395
CBSF2000	2,000 Lb. Clamp-on Bucket Bale Spear Chain and turnbuckle system. 42" long Single tapered forged tine for use with tight center bales.	79 lbs.	\$465
CBSF2028	3000 Lb. Clamp-on bucket Uses chain and turnbuckle system. Two 42" tapered forged spears	102 lbs.	\$719
CBSF3028	4000 Lb. Clamp-on bucket THREE bales spear. Uses 2 chains & turnbuckle system. Three 42" tapered forged spears	185 lbs.	\$1039

# HAY HANDLING ATTACHMENTS

## Front Loader or Skid Steer



MODEL	DESCRIPTION	WEIGHT	LIST PRICE
FLBS2200	2200 lb. rated Single Loader Bale Spear Single 42" tapered forged spear. Requires Optional Interfacing. Quick Attach Brackets (not included)	121 lbs.	\$559
FLBS3000	3000 lb. rated Dual Loader Bale Spear Two 42" forged tapered Spears. Requires Optional Interfacing Quick Attach Brackets (not included)	136 Lbs.	\$659



MODEL	DESCRIPTION	WEIGHT	LIST PRICE
SSB3000	Skid Steer Double Bale Spear. Rated at 3000 lbs. Bolt-in tapered spears have usable length of 42". Designed to fit "universal" skid steer quick attach system	146 lbs.	\$759

# HAY HANDLING ATTACHMENTS

## 3 Pt. Hitch Only



BSF1523



HHU2045

### BALE SPEAR

MODEL	DESCRIPTION	WEIGHT	LIST PRICE
BSF1523	1,800 Lb. 3 pt. Bale Spear Cat. 1 & 2. Single spear is 44" tapered forged spear for excellent penetration into the bale, w/welded balance spears.	60 lbs.	\$299

### HAY HANDLER / BALE UNROLLER

MODEL	DESCRIPTION	WEIGHT	LIST PRICE
HHU2045	2,000 Lb. 3 Pt. Hay Handler/Unroller 4' to 5' width & up to 6' diameter bales. Cat. 1, 2 & 3. 3 Narrow Quick Hitch. Use 2.5" x 8" Hydraulic Cylinder (Not included.)	310 lbs.	\$1239



# HAY HANDLING ATTACHMENTS

## Bale Huggers Front Loader Mount



UBH2000



UBH2072

MODEL	DESCRIPTION	WEIGHT	LIST PRICE
UBH2000	2,000 Lb. Bale Hugger For 4' to 6' wrapped or unwrapped bales. Hydraulic cylinder included. Loader mounting brackets extra. Pin type or quick attach available.	435 lbs.	\$2439
UBH2072	2,200 Lb. Bale Handler For 4' to 6' wrapped or unwrapped bales. Hydraulic cylinder included. Loader mounting brackets extra. Pin type or quick attach available.	529 lbs.	\$2749

# HAY HANDLING

## Bale Huggers Skid Steer Mount



SSBH2072

MODEL	DESCRIPTION	WEIGHT	LIST PRICE
SSBH2072	2,200 Lb. Bale Handler For 4' to 6' wrapped or unwrapped bales. Hydraulic cylinder included. Comes with universal skid steer quick attach mounting bracket.	470 lbs.	\$3139

# HAY HANDLING ATTACHMENTS RW Spin Off



Designed as an efficient hay management tool for moving and feeding round bales. The Spin Off hydraulically rotates the bale, unwinding the hay into a windrow.

- \* Eliminates wasted hay, only unroll what cattle will clean up in one hour
- \* Easy operation from cab of tractor or skid steer
- \* 3 Pt. hitch, front tractor loader or skid steer mount available
- \* Hydraulically driven for better operator control
- \* Rotates in both directions for easy feeding
- \* Cushion valve in the motor provides protection for hydraulic components
- \* 44" forged tapered spear
- \* GPM Requirement 8-10 GPM. Min. 1500 PSI
- \* 3 pt. & skid steer models include hyd. hoses, tractor loader mount, less hyd. hoses. Less hyd. couplers

MODEL	DESCRIPTION	WEIGHT	LIST PRICE
FSO906	3 Pt Hitch Cat II/III Can be converted to Cat 1 with bushings & Cat 1 pins, (not included). Includes 2 hyd hoses, less couplers	250 lbs.	\$2679
FLSO907	Front tractor loader mount Less hyd hoses, less loader mounting brackets Optional brackets for most loader makes available	370 lbs.	\$2939
SSSO908	Skid Steer Mount Includes "Universal" skid steer quick attach bracket. Includes 2 hyd hoses (less couplers)	325 lbs.	\$3209

# POTATO Planter, Hiller & Digger



This unique implement will do all three tasks with the greatest of ease. Attach the seat and rear cover board and plant your potatoes with ease. In mid-season bolt on the 18" sweep and hill the potatoes. At harvest time, go down the centre of the row with the sweep and watch the potatoes roll out on either side. Works like a dream.

- \* Cat. 1 3 Pt. hitch
- \* HP Requirements: 25

MODEL	DESCRIPTION	LIST PRICE
1700166	3-in-1 Potato Planter, Hiller and Digger	\$859

# 3 PT. MOLDBOARD PLOWS



6214



6112

as shown with optional  
MP080017 depth gauge kit,  
MP080018 coulter blade kit

These 3 Pt. hitch Cat.1 moldboard plows are ideal for the small acreage plowing. For sub compact and compact tractors. Made from heavy 1" x 4" steel bar with replaceable shares and moldboards. Optional depth control and coulter kits available.

MODEL	DESCRIPTION	WEIGHT	LIST PRICE
6112	One 12" Bottom Plow	290 lbs.	\$699
6114	One 14" Bottom Plow	300 lbs.	\$725
6214	Two 14" Bottom Plow	490 lbs.	\$1199
6216	Two 16" Bottom Plow	520 lbs.	\$1225

## **OPTIONS:**

MODEL	DESCRIPTION	LIST PRICE
MP080017	Depth Gauge Kit	\$115
MP080018	Coulter Blade Kit	\$139

One Coulter Blade Kit Required per Bottom

# PACKERS

## 3 Pt.



- \* Designed for 40 to 80 HP tractors
- \* 3 Pt hitch Cat. I - 6', Cat. I / II - 8' & 12'
- \* Heavy duty 4" square tube steel main frame
- \* 16" cast iron sprocket packer wheels
- \* Heavy duty 1-1/8" gang axle wth ball bearings
- \* Parking stands

MODEL	DESCRIPTION	WEIGHT	LIST PRICE
BCP1816	6' working width packer	1035 lbs.	\$3249
BCP2416	8' working width packer	1300 lbs.	\$4179
BCP3616	12' working width packer	1885 lbs.	\$6169

Weights indicated are base machine weight, not shipping weight

# POST HOLE DIGGERS

## 3 Pt. PTO & Hydraulic



500WS PHD



720 PHD



624H PHD



Fish Tail Point



102165  
Parking stand



925 PHD



DFK50-70-90



924H PHD



824H PHD

# POST HOLE DIGGERS

## 3 Pt. PTO & Hydraulic



- \* Heavy duty tubular steel stock on yoke & booms
- \* Large 2" round output shaft has two bolt auger connection
- \* Shear pin protected & shielded PTO drivelines.
- \* Down force kits available
- \* 3 position boom adjustment on PTO models
- \* 5 year limited gearbox warranty
- \* Trouble free tapered roller bearings & spring loaded seals
- \* Choose from a large selection of 9", 12" by 30" long, single flight and 6" to 30' x 42" long, double flight all with Fish Tail auger points
- \* Parking Stands available.
- \* 924HC/EURO fits directly onto ALO loaders
- \* Model 624H Includes hydraulic hoses.
- \* Models 724H, 824H, 924H, 924HC/EURO. Do Not Include hydraulic hoses

MODEL	GEAR RATIO	HITCH SIZE	AUGER LENGTH	AUGER USAGE	WEIGHT	LIST PRICE
<b>3 PT. HITCH 540 RPM PTO</b>						
300	3:1	Cat. 0	30"	9" - 12"	149 lbs.	\$859
500WS	3:1	Cat. 1 and 2	42"	6" - 12"	160 lbs.	\$879
720	3.18:1	Cat. 1 and 2	42"	6" - 24"	206 lbs.	\$1129
925	4.1:1	Cat. 1 and 2	42"	6" - 30"	210 lbs.	\$1419
<b>HYDRAULIC DRIVE, Requires 10-20 gpm @ 1500-3000 psi</b>						
624H	3Pt. hitch Cat 1 & 2 (inc. hyd hoses)			6" - 24"	182 lbs.	\$2099
724H	Loader (bolt-on side plate)			6" - 24"	127 lbs.	\$1899
824H	Loader (clamp-on)			6" - 24"	196 lbs.	\$2099
924H	Skid steer quick attach mount			6" - 24"	210 lbs.	\$1979
924HC	ALO loader mount			6" - 24"	220 lbs.	\$1979

### AUGERS

MODEL	DESCRIPTION	WEIGHT	LIST PRICE
9SF	9" Single flight 30" long	25 lbs.	\$195
12SF	12" Single flight 30" long	28 lbs.	\$199
6HDDF	6" Double flight 42" long	32 lbs.	\$235
9HDDF	9" Double flight 42" long	47 lbs.	\$265
12HDDF	12" Double flight 42" long	54 lbs.	\$309
14HDDF	14" Double flight 42" long	76 lbs.	\$369
18HDDF	18" Double flight 42" long	98 lbs.	\$569
24HDDF	24" Double flight 42" long	128 lbs.	\$739
30HDDF	30" Double flight 42" long	190 lbs.	\$949

### OPTIONS:

MODEL	DESCRIPTION	WEIGHT	LIST PRICE
170705	12" Auger Extension (extends 42" augers to 54")	16 lbs.	\$209
DFK50	*Down force kit for model 500WS	39 lbs.	\$550
DFK70	*Down force kit for model 720, 624H	40 lbs.	\$590
DFK90	*Down force kit for model 925	42 lbs.	\$590
*Kit contains hydraulic cylinder & hoses			
102160	Parking stand for model 300	11 lbs.	\$125
102165	Parking stand for model 500/720	12 lbs.	\$139
102170	Parking stand for model 925	13 lbs.	\$155

Weights indicated are base machine weight, not shipping weight

# POST DRIVERS

## 3 Pt. Hitch



Hydraulic Adjust



Manual Adjust

Installing new fencelines? Replacing old ones? **WORKSAVER** post drivers are built to last with quality features designed to improve operator convenience, versatility, production and performance in all kinds of conditions. Available with either manual adjustment crank or hydraulic cylinder controlled for post alignment

### WITH MANUAL ADJUSTMENT

	HPD16	HPD22Q	HPD26Q
Maximum post size	5" x 9'	8 3/4" x 10'	11" x 10'
Impact at full stroke	32,000 lbs.	80,000 lbs.	110,000 lbs.
Impact at half stroke	16,000 lbs.	40,000 lbs.	55,000 lbs.
Hydraulic requirements	3 - 4 gpm	6 - 8 gpm	12 gpm
Minimum tractor size	20 - 22 HP	30 - 35 HP	50 - 55 HP
Hitch Type	Cat. I or II	Cat. I or II	Cat. II
Weight	600 lbs.	795 lbs.	N/A
<b>LIST PRICE</b>	<b>\$3599</b>	<b>\$4979</b>	<b>N/A</b>

### WITH HYDRAULIC ADJUSTMENT

	HPD16SHC	HPD22QSHC	HPD26QSHC
Tilt Adjustment	- Front/Back 17° each way from vertical	- Side/Side 20° each way from vertical	
# of Tilt Cylinders	-Two (2) 3" x 6"		
Weight	875 lbs.	1035 lbs.	1215 lbs.
<b>LIST PRICE</b>	<b>\$6089</b>	<b>\$7499</b>	<b>\$9099</b>



# POST DRIVERS

## Skid Steer



Hydraulic Adjust



Manual Adjust



Installing new fence lines? Replacing old ones? Setting post for livestock pens, feedlots, vineyards, etc. save time and eliminate backbreaking labour with a **WORKSAVER** Skid steer Post Driver.

### WITH MANUAL ADJUSTMENT & UNIVERSAL STYLE QUICK ATTACH BRACKETS

(SPECIAL Order, not stocked)

	HPD16MSS	HPD22QMSS
Maximum post size:	5" x 9'	8-3/4" x 10'
Impact at full stroke:	32,000 lbs.	80,000 lbs.
Impact at half stroke:	16,000 lbs.	40,000 lbs
Minimum hydraulic req.:	3 - 4 gpm	6 - 8 gpm
Mount Type	Skid Steer	Skid Steer
Weight:	678 lbs.	828 lbs.
<b>LIST PRICE</b>	<b>\$4499</b>	<b>\$5899</b>

### WITH HYDRAULIC ADJUSTMENT & UNIVERSAL STYLE QUICK ATTACH BRACKET

(SPECIAL Order, not stocked)

	HPD16HSS	HPD22QHSS	HPD26QHSS
Tilt Adjustment	- Front/Back 17° each way from vertical - Side/Side 20° each way from vertical		
# of Tilt Cylinders	-Two (2) 3" x 6"		
Maximum post size	5" x 9'	8-3/4" x 10'	11" x 10'
Impact at full stroke	32,000 lbs.	80,000 lbs.	110,000 lbs.
Impact at half stroke	16,000 lbs.	40,000 lbs.	55,000 lbs.
Hydraulic requirements	3 - 4 gpm	6 - 8 gpm	12 gpm
Mount Type	Skid Steer	Skid Steer	Skid Steer
Weight	950 lbs.	1245 lbs.	1429 lbs.
<b>LIST PRICE</b>	<b>\$7059</b>	<b>\$8459</b>	<b>\$9999</b>

**NOTE:** Return line package required depending on make and model of skid steer (order extra), please advise model of skid steer when ordering post driver return line.

# SINGLE SHANK RIPPERS 3 PT. HITCH



MBP-36



R-130

**WORKSAVER** offers the following tillage equipment for customers with compact or smaller horsepower tractors. All of this equipment is shear bolt protected.

MODEL	DESCRIPTION	WEIGHT	LIST PRICE
MBP36	Economy middle buster with 15" shovel shear bolt protected Cat. 0 and 1, 3 Pt. hitch 15 to 25 HP	77 lbs.	\$419
R130	Heavy duty single shank ripper with 30" shank on a 31" frame Cat. 1 and 2, 3 Pt. hitch reversible point, shear bolt protected	218 lbs.	\$1059

# SUB-SOILERS

## 3 Pt. Hitch



These quality constructed one, two and three shank sub-soilers are constructed of 5" x 7" heavy wall steel tubing for maximum strength. The shanks are constructed of T1 steel, 1-1/4" thick with a replaceable heat treated point and are shear pin protected. Parking stands are standard equipment. Designed for 30 - 130 HP tractors.

MODEL	SHANKS	WEIGHT	FRAME LENGTH	SHANK SPACING	LIST PRICE
1S28T1	(2) 28"	243 lbs.	26"	0"	\$1479
2S2860T1	(2) 28"	609 lbs.	60"	52"	\$2939
2S2880T1	(2) 28"	655 lbs.	80"	72"	\$3049
3S3290T1 Dble. Bar	(3) 32"	1264 lbs.	90"	Adjustable	\$5079

**When using sub-soilers in rocky conditions, warranty will be considered for manufacturers defects only, not for damage from sub-terranean obstacles.**

# DISC HARROWS

## "THE" Series

### 3 Pt. Hitch



The Monroe Tufline THE series 3 Pt. hitch disc harrows are designed for 25HP to 35HP tractors. Available in 5'6", 6'4" & 6'8" cutting widths with category I 3 Pt. hitch. 3" square tube frame, 1" square high strength steel gang axles, 7 1/2" or 9" blade spacing & 18" notched disc blades. Sealed gang bearings, lever adjusting gang angles. Optional blade scrapers are available.

- \* 3" Square steel tube frame
- \* Cat I, 3 Pt. hitch
- \* 18" Notched disc blades
- \* 7 1/2" or 9" blade spacing
- \* Adjustable gang angle
- \* 1" High strength gang axle
- \* Sealed flange mounted gang ball bearings

MODEL	# BLADES	BLADE SPACING	WIDTH	WEIGHT	LIST PRICE
1THE71618BF	16	7 1/2"	5'6"	659 lbs.	\$2059
1THE72018BF	20	7 1/2"	6'8"	732 lbs.	\$2329
1THE91618BF	16	9"	6'4"	718 lbs.	\$2149
1THE971818BF	18	9" Front 7 1/2 Rear	6'8"	736 lbs.	\$2259

#### OPTIONAL SCRAPER KITS

MODEL	FITS MODEL	WEIGHT	LIST PRICE
RSK716L	1THE716	65 lbs.	\$429
RSK720L	1THE720	82 lbs.	\$499
RSK916L	1THE916	72 lbs.	\$449
RSK9718L	1THE9718	80 lbs.	\$459

# OFFSET DISC "TLO" Series 3 Pt. Hitch



The Monroe Tufline TLO series 3 Pt. hitch offset discs are designed for 25 to 75HP tractors. Available in 4'6" to 8'4" cutting widths with category I or II 3 Pt. hitch. Units come with 3" square tube frame, 1 1/8" square high strength steel gang axles, 9" blade spacing, 20" disc blades & sealed gang bearings. Unit also has pin adjusting gang angles and front to rear leveling for side draft control. Optional blade scrapers are available.

- \* 3" Square steel tube frame
- \* Cat I or II, 3 Pt. hitch
- \* 1 1/8" High strength gang axle
- \* 9" Blade spacing
- \* Adjustable gang angle
- \* Pressure control levelling
- \* 20" Notched disc blades
- \* Sealed gang ball bearings

MODEL	# BLADES	CUTTING WIDTH	WEIGHT	LIST PRICE
TLO91220	12	4'6"	710 lbs.	\$2349
TLO91420	14	5'3"	996 lbs.	\$3429
TLO91620	16	6'	1101 lbs.	\$3689
TLO91820	18	6'8"	1185 lbs.	\$3939
TLO92020	20	7'6"	1250 lbs.	\$4149
TLO92220	22	8'4"	1318 lbs.	\$4359

## OPTIONAL SCRAPER KITS

MODEL	FITS MODEL	WEIGHT	LIST PRICE
SLO912	TLO912	144 lbs.	\$669
SLO914	TLO914	156 lbs.	\$699
SLO916	TLO916	192 lbs.	\$739
SLO918	TLO918	207 lbs.	\$779
SLO920	TLO920	224 lbs.	\$839
SLO922	TLO922	250 lbs.	\$879

# DISC HARROWS

## "TW6" Series

### Pull Type



The TW6 Series Tandem Discs are heavy engineered discs designed for primary tillage applications. The TW6 is available in 10', 12', 13', & 15' working widths. Constructed of heavy 6" x 4" and 4" square steel frames. Blade spacing available in 9" or 10-1/2" with 24" plain or notched 6 mil disc blades on 1-1/2" cold drawn square gang axles. Gangs are mounted with triple sealed ball bearings (optional regreaseable bearings available) in a ductile cast trunnion housing with hi-strength tube style or shock flex (c-shank) gang hangers. All units offer adjustable gang cutting angle, front to rear leveling system and depth control.

- \* **Heavy 6" x 4" and 4" Square Steel Frame**
- \* **Dual Wheel Carriage with 4 – 9.5L x 15 6 Ply Implement tires**
- \* **Front to Rear Leveling System**
- \* **Depth Control System**
- \* **Adjustable Gang Cutting Angle**
- \* **1-1/2" Square cold Drawn Steel Gang Axle**
- \* **9" or 10-1/2" Blade Spacing**
- \* **24" 6 mil Plain or Notched Disc Blades (Customer Choice)**
- \* **Triple Sealed Trunnion Mount Gang Ball Bearings**
- \* **Available with Tube Style or Shock Flex Gang Hangers**
- \* **Includes Implement Tongue Jack, Safety Chain,**
- \* **Includes 4"X 8" Hydraulic Cylinder, Set of Hydraulic Hoses**
- \* **Options Available**
  - Regreaseable Gang Ball Bearings**
  - Heavy Adjustable Blade Scrapers**

# DISC HARROWS



## "TW6" Series

Pull Type

### 9" SPACING

MODEL	BLADES	# OF BRGS	WIDTH	TUBE WT. (LBS)	TUBE LIST	SHOCK FLEX WT. (LBS)	SHOCK FLEX LIST
TW692824	(28) 24"	8	10' 6"	4401 lbs	\$13,899	4869 lbs	\$14,999
TW693224	(32) 24"	8	12'	4794 lbs	\$14,999	5212 lbs	\$16,179
TW693624	(36) 24"	12	13' 4"	5158 lbs	\$16,639	5576 lbs	\$18,399
TW694024	(40) 24"	12	15'	5539 lbs	\$18,119	5975 lbs	\$19,999

### 10-1/2" SPACING

MODEL	BLADES	# OF BRGS	WIDTH	TUBE WT. (LBS)	TUBE LIST	SHOCK FLEX WT. (LBS)	SHOCK FLEX LIST
TW6102424	(22) 24"	8	10' 6"	4279 lbs	\$12,879	4883 lbs	\$13,999
TW6102824	(28) 24"	8	12'	4570 lbs	\$14,489	4886 lbs	\$15,619
TW6103224	(32) 24"	12	13' 4"	4970 lbs	\$15,989	5324 lbs	\$17,699
TW6103624	(36) 24"	12	15'	5319 lbs	\$17,619	5737 lbs	\$19,329

Add "SF" to model # when ordering disc equipped with shock flex gang hangers

## TW6 SERIES SCRAPER KITS

### 9" SPACING

MODEL	USED ON	WEIGHT (LBS.)	LIST PRICE
SK928/6	TW6928	320	\$1159
SK932/6	TW6935	353	\$1279
SK936/6	TW6936	441	\$1379
SK940/6	TW6940	479	\$1489

### 10-1/2" SPACING

MODEL	USED ON	WEIGHT (LBS.)	LIST PRICE
SK1024/6	TW61024	298	\$1029
SK1028/6	TW61028	326	\$1179
SK1032/6	TW61032	406	\$1279
SK1036/6	TW61036	448	\$1389

### TW6 SERIES OPTIONS:

MODEL	DESCRIPTION	LIST PRICE
T703-18	(Pair) Outrigger kit (Furrow Filler)	\$275
11476	Balk breaker with point	\$249
13188	Regreasable gang ball bearings	\$32

Weights indicated are base machine weight, not shipping weight

# OFFSET DISC "42" Series



- \* Includes 4" x 8" Hydraulic Cylinder with hydraulic hoses (less coupler plugs)
- \* Implement Tongue Jack, Safety Chain, SMV Sign
- \* Standard with Notched Disc Blades
- \* HP Requirements: 60-120 (Approx. 10 HP per Ft.)
- \* Tongue and yoke system for side draft
- \* Gang angles adjust by turnbuckles
- \* Triple sealed ball bearings in trunnion mount
- \* Dual wheels on all models includes 9.5L x 15 6 ply implement tires
- \* 24" and 26" disc blades - 1/4" thick
- \* Shock flex gang hangers for rocky soil conditions
- \* 6" x 4" heavy wall tube frame
- \* 1-1/2" RC square cold drawn axle
- \* Front and rear levelling system

### OPTIONAL EQUIPMENT

- \* Blade scrapers, Plain (Smooth) Blades, Regreasable Gang Bearings, Furrow Filler Kit (see page 145 OPTIONS)

## 9" SPACING

MODEL	BLADES	# OF BRGS	WIDTH	SHOCK FLEX WT. (LBS)	SHOCK FLEX LIST
42/91824SF	(18) 24"	8	6' 8"	3907	\$13,289
42/91826SF	(18) 26"	8	6' 8"	4038	\$13,759
42/92024SF	(20) 24"	8	7' 8"	4000	\$13,689
42/92026SF	(20) 26"	8	7' 8"	4166	\$14,209
42/92224SF	(22) 24"	8	8' 4"	4250	\$14,109
42/92226SF	(22) 26"	8	8' 4"	4396	\$14,689
42/92424SF	(24) 24"	8	9'	4540	\$14,459
42/92426SF	(24) 26"	8	9'	4672	\$15,099
42/92824SF	(28) 24"	12	10' 4"	4868	\$15,989
42/92826SF	(28) 26"	12	10' 4"	5047	\$17,339
42/93224SF	(32) 24"	12	12' 3"	5161	\$17,639
42/93226SF	(32) 26"	12	12' 3"	5344	\$18,379
42/93624SF	(36) 24"	14	13' 3"	5311	\$19,269
42/93626SF	(36) 26"	14	13' 3"	5655	\$20,199



# OFFSET DISC "42" Series



## 10-1/2" SPACING

MODEL	BLADES	NO. OF BRGS.	WIDTH OF CUT	SHOCK FLEX WGT. (LBS.)	SHOCK FLEX LIST
42/101824SF	(18) 24"	8	8'	4002	\$13,449
42/101826SF	(18) 26"	8	8'	4010	\$13,919
42/102024SF	(20) 24"	8	9'	4228	\$13,699
42/102026SF	(20) 26"	8	9'	4360	\$14,229
42/102224SF	(22) 24"	8	9' 10"	4394	\$14,159
42/102226SF	(22) 26"	8	9' 10"	4526	\$14,729
42/102424SF	(24) 24"	8	10' 6"	4649	\$14,839
42/102426SF	(24) 26"	8	10' 6"	4807	\$15,469
42/102824SF	(28) 24"	12	12'	5164	\$17,299
42/102826SF	(28) 26"	12	12'	5314	\$17,999
42/103224SF	(32) 24"	12	13' 9"	5278	\$17,789
42/103226SF	(32) 26"	12	13' 9"	5500	\$18,629

## 42 Series SCRAPER KITS

### 9" SPACING

MODEL	USED ON	WEIGHT (LBS.)	LIST PRICE
OSK42/918	42/918	276	\$809
OSK42/920	42/920	294	\$879
OSK42/922	42/922	325	\$949
OSK42/924	42/924	359	\$999
OSK42/928	42/928	460	\$1189
OSK42/932	42/932	527	\$1329
OSK42/936	42/936	580	\$1439

### 10-1/2" SPACING

MODEL	USED ON	WEIGHT (LBS.)	LIST PRICE
OSK42/1018	42/1018	277	\$799
OSK42/1020	42/1020	303	\$909
OSK42/1022	42/1022	330	\$939
OSK42/1024	42/1024	352	\$999
OSK42/1028	42/1028	410	\$1199
OSK42/1032	42/1032	527	\$1299

### 42 SERIES OPTIONS:

MODEL	DESCRIPTION	LIST PRICE
T703-1/2-20	Furrow Filler	\$160
13188	Additional charge for regreasable gang brgs. 1-1/2"	\$32

### TO PRICE AN OFFSET DISC MAKE SURE YOU HAVE PRICED:

1. Scraper kit (If Required)
2. Any applicable options from the option list
3. Remember your spacing - 9" or 10-1/2" available
4. Order blades plain, notched, or a combination

# TRACTOR CANOPIES JUNIOR

**BARE-Co**



B3580 Shown



B3581 Shown

The **BARE-Co** junior canopy is moulded from virtually indestructible flexible U.V. stabilized polyethylene. The canopy is 34" wide x 47" long and is designed moulded to hug modern hoop type ROPS frames. Available in standard colours, with two mounting kits to fit most compact & sub-compact tractors ROPS frames.

MODEL	DESCRIPTION	WEIGHT	PRICE
B2581	White Canopy	20 lbs.	\$380
B2582	Green Canopy	20 lbs.	\$380
B2583	Orange Canopy	20 lbs.	\$380
B2584	Blue Canopy	20 lbs.	\$380
B2585	Red Canopy	20 lbs.	\$380
B2586	Yellow Canopy	20 lbs.	\$380
B3580	Mounting Kit Mounts canopy to HOOP, CURVED or SQUARE TOP Both rigid or folding up to 30" wide with leg thickness up to 3-3/16" x 2"	17 lbs.	\$175
B3581	Mounting Kit Mounts the canopy OVERWIDTH ROPS frames with a width of more than 30" wide, with a leg thickness from 2" x 2" to 2" x 4"	13 lbs.	\$135

# TRACTOR CANOPIES SENIOR

**BARE-Co**



B3600 Shown



B2565 Shown

The **BARE-Co** standard canopy is moulded from virtually indestructible flexible U.V. stabilized polyethylene. The canopy is 45" wide x 60" long and is designed moulded to hug modern hoop type ROPS frames. Available in standard colours, with three mounting kits to fit most types of ROPS frames.

MODEL	DESCRIPTION	WEIGHT	PRICE
B2570	White Canopy	29 lbs.	\$470
B2571	Green Canopy	29 lbs.	\$470
B2572	Orange Canopy	29 lbs.	\$470
B2573	Blue Canopy	29 lbs.	\$470
B2580	Red Canopy	29 lbs.	\$470
B3600	Mounting Bracket Mounts the canopy to any folding or rigid hoop type ROPS frame up to 41-1/2" wide, with leg thickness up to 3-3/16" x 2"	17 lbs.	\$185
B2565	Mounting Bracket Mounts the canopy to overwidth ROPS frames, crossbar or leg width more than 41-1/2", leg thickness from 2" x 2" to 2" x 4"	13 lbs.	\$149
B4620	Mounting Bracket Mounts the canopy to ROPS frames up to 41-1/2" wide with leg thicknesses of 4" x 4", 5" x 2" or 6" x 2"	21 lbs.	\$269

# QUICK HITCHES



**WORKSAVER** quick hitches are built for fast, safe and easy connection and disconnection of 3 Pt. implements. The **WORKSAVER** quick hitches fit most Category 1, 2 and 3 Pt. hitch tractors.

- A** Inside Hooks
- B** Outside Hooks
- C** Centerline Distance of lower pin to upper pin
- D** Pocket sized for 1-7/16" pins or bushings

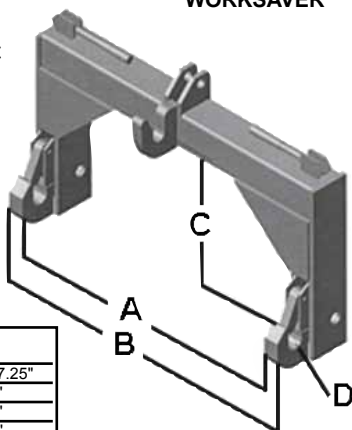

MODEL	QUICK HITCH SPECIFICATIONS		
	A	B	C
QH10178	25.75"	29.50"	14.50" - 17.25"
QH102	32.75"	36.25"	14.88"
QH107HD	32.50	37.75"	14.88"
QH1023	38.25"	43.15"	18.88"
QH103	38.25"	43.50"	18.88"
QH106N	32.63"	37.00"	19.00"

- \* High strength tubing for torsional strength
- \* Over-center spring loaded latch mechanism provides positive lock yet easy equipment release
- \* Solid frame cut parts for long life
- \* Reinforced at known wear points
- \* Non-rotating adapter bushings for wear resistance
- \* Rubber handle grips on latch handles
- \* Tapered top hitch point bracket for easy hook-up
- \* Includes one set adapter bushings with QH101, QH102, QH107HD

MODEL	DESCRIPTION	WEIGHT	LIST PRICE
QH10178	Cat. 1 (up to 50 HP)	76 lbs.	\$419
QH102	Cat. 2 (up to 100 HP)	134 lbs.	\$575
QH107HD	Cat. 2 HD (up to 150 HP)	160 lbs.	\$679
QH1023	Cat. 2 to Cat. 3 Allows use of Cat. 3 implements on tractors with Cat. 2, 3 Pt hitch	185 lbs.	\$809
QH103	Cat. 3 (up to 225 HP)	182 lbs.	\$809
QH106N	Cat. 3 Narrow (up to 225 HP)	176 lbs.	\$809

## HYDRAULIC TOP LINK



TLC3110

MODEL	DESCRIPTION	LIST PRICE
TLC3110	Hydraulic top link Cat. II, 3" bore x 10" stroke, 1-1/4" dia. shaft 21" closed, 1/2" ports, 2500 PSI working pressure	\$375

# LOADER BRACKETS QUICK ATTACH



## Euro/Global/Alo to Skid Steer Adaptor



832550

WorkSaver is introducing a "NEW" interfacing adaptor, designed to allow the use of skid steer attaching system to be used on loaders with the Euro style quick attach system. This all welded design, features plated handles, springs and lock pins. In addition, the customer can easily switch attachments between a skid steer loader and a tractor loader.

MODEL	DESCRIPTION	WEIGHT	PRICE
832550	Euro to skid steer adaptor	110 lbs.	\$829

## Weld-On Skid Steer Bracket

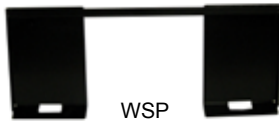

WSP

## Weld-On Euro/Global/Alo Quick Attach Brackets



Left Hand

ALO1

Right Hand

The WSP plate simply welds to existing attachment i.e. bucket, stone fork etc. to convert to "Universal" skid steer quick attach mounting.

MODEL	DESCRIPTION	WEIGHT	PRICE
WSP	Weld-on plate	46 lbs.	\$175
ALO1	2 pc. Weld-on Euro/Global/Alo quick attach brackets	36 lbs.	\$140

## Universal Skid Steer Quick Attach Brackets

This plate can u-bolt to any attachment to mount to skid steer universal quick attach



MODEL	DESCRIPTION	WEIGHT	PRICE
831110	Universal skid steer quick attach to u-bolt implement plate	95 lbs.	\$319

# ROTARY BROOMS SKID STEER MOUNT



The WORKSAVER skid steer hydraulically driven rotary broom fits any make and model of skid steer with universal skid steer quick attach mounting. Hydraulic motor rated @ 16GPM continuous operation for maximum brush speed. Optional manual or hydraulic angling kit available. All hydraulic hoses sheathed and routed through integral loops for maximum protection. Flat-faced "connect under pressure" hydraulic couplers standard

- \* **Universal skid steer quick attach mounting**
- \* **16 GPM hydraulic motor**
- \* **4.36 / 1 chain drive ratio to broom for excellent torque**
- \* **Heavy duty #60 drive roller chain**
- \* **Parking stands**
- \* **Step-through mount design for easy in/out of skid steer cab**
- \* **Greaseable pivot points for long life**
- \* **32" diameter poly or poly/wire brush**
- \* **Optional manual or hydraulic angle adjustment kit available**

MODEL	DESCRIPTION	WEIGHT	PRICE
SSMB325P	5'/60" Wide Rotary Broom with Poly Brush	630 lbs.	\$6819
SSMB325PW	5'/60" Wide Rotary Broom with Poly/Wire Brush	630 lbs.	\$6819
SSMB326P	6'/72" Wide Rotary Broom with Poly Brush	730 lbs.	\$7249
SSMB326PW	6'/72" Wide Rotary Broom with Poly/Wire Brush	730 lbs.	\$7249
SSMB327P	7'/84" Wide Rotary Broom with Poly Brush	830 lbs.	\$7989
SSMB327PW	7'/84" Wide Rotary Broom with Poly/Wire Brush	830 lbs.	\$7989

## **OPTIONS:**

	DESCRIPTION	LIST PRICE
610702	Manual Angle Adjustment Kit	\$175
610703	Hydraulic Angle Adjustment Kit	\$539
610940	Hydraulic Angle Adjustment Kit with Electric Hydraulic Solenoid control. For skid steer rotary Brooms used on units equipped with only one set of remotes, inc'ds hyd. cylinder, hoses, valve, & flat faced couplers, Factory Installed	\$1775

# ROTARY BROOMS

## 3 Pt. HITCH PTO



The WORKSAVER 3 Pt. hitch 540 RPM PTO Rotary Broom mounts to any tractor with 540 RPM PTO. Keep your tractor and sweeper busy all year sweeping snow, dirt, thatch, leaves and other debris. Sweeps forward and can wind-row debris, to the front, right or left. If you reverse broom rotation, pulling action cleans thatch with out damaging grass. Mechanical brush drive, with optional manual angle, 30 degrees right or left, or optional hydraulic angle available. Height adjustment chains maintains even operating position. 32" diameter broom is available in poly, or combo 50/50 poly/wire. A double gearbox drive is used for smooth power transmission and low maintenance. Top "T-Shaft" gearbox allows for easy reversal of brush rotation.

- \* Cat. 1, 3 Pt. hitch
- \* 540 RPM PTO
- \* Optional Manual or hydraulic angle  
30 degrees right or left
- \* Height adjustment chains
- \* 32" diameter brush
- \* Available in Poly, or 50/50 Poly/Wire brush
- \* Double gearbox drive
- \* Top "T-Shaft" gearbox allows easy reversal of brush rotation

MODEL	DESCRIPTION	WEIGHT (LBS.)	LIST PRICE
RMB325P	5' Wide rotary broom with poly brush	640 lbs.	\$6349
RMB325PW	5' Wide rotary broom with poly/wire brush	640 lbs.	\$6349
RMB326P	6' Wide rotary broom with poly brush	740 lbs.	\$6659
RMB326PW	6' Wide rotary broom with poly/wire brush	740 lbs.	\$6659
RMB327P	7' Wide rotary broom with poly brush	840 lbs.	\$7269
RMB327PW	7' Wide rotary broom with poly/wire brush	840 lbs.	\$7269

### OPTIONS:

MODEL	DESCRIPTION	LIST PRICE
610702	Manual Angle Kit	\$175
610703	Hydraulic Angle Kit with hoses	\$539

Weights indicated are base machine weight, not shipping weight

# WWW.FARMFLEET.COM

23703 Wellburn Rd.  
St. Marys, ON N4X 1C6  
Tel: 519-461-1499  
Fax: 519-461-1599

839 McLellans Brook Rd.  
New Glasgow, NS B2H 5C5  
Tel: 902-755-0858  
Fax: 902-755-2362

**Email: [farmfleet@execulink.com](mailto:farmfleet@execulink.com)**



• Your Local Farm-Fleet Dealer •